

TX-28/25XD60P / TX-28/25XD60S Service Manual

Safety

Specifications

Parts List

Service
Information

Adjustments

Self Check

Service Hints

Mechanical
View

Disassembly

Location of
Controls

Waveforms

Block Diagrams

Schematic Diagrams

PCB Views

Service Support

Service and repair of this product is supported by Panasonic's LUCI interface.

This interface provides a link between the TV and a standard PC to allow a number of diagnostic and control functions to be performed.

For more details contact your local Panasonic company.

BACK

EXIT

Video / Audio

Control



BACK

B2 - PCB

D - PCB

E - PCB

F2 - PCB

H - PCB

Y - PCB

B2 - Schematic

D - Schematic

E - Schematic

F2 - Schematic

H - Schematic

M3 - Schematic

Y - Schematic



BACK



BACK

Service Manual



Colour Television

TX-28XD60P/TX-25XD60P TX-28XD60S/TX-25XD60S EURO-3H Chassis

SPECIFICATIONS

(Information in brackets {} refer to TX-25XD60P/TX-25XD60S)

Power Source :	220-240V AC, 50Hz												
Power Consumption :	<table> <tr> <td>TX-28XD60P</td> <td>205W</td> </tr> <tr> <td>TX-25XD60P</td> <td>205W</td> </tr> <tr> <td>TX-28XD60S</td> <td>155W</td> </tr> <tr> <td>TX-25XD60S</td> <td>150W</td> </tr> </table>	TX-28XD60P	205W	TX-25XD60P	205W	TX-28XD60S	155W	TX-25XD60S	150W				
TX-28XD60P	205W												
TX-25XD60P	205W												
TX-28XD60S	155W												
TX-25XD60S	150W												
Standby Power Consumption :	1W												
Aerial Impedance :	75Ω unbalanced, Coaxial Type												
Receiving System :	PAL-I, B, G, D, K, H, PAL 60, SECAM B, G, D, K, L/L' MNTSC, NTSC (AV Only)												
Receiving Channels :	<table> <tr> <td>VHF E2 - E12</td> <td>VHF H1 - H2 (ITALY)</td> </tr> <tr> <td>VHF A - H (ITALY)</td> <td>VHF R1 - R2</td> </tr> <tr> <td>VHF R3 - R5</td> <td>VHF R6 - R12</td> </tr> <tr> <td>UHF E21 - E69</td> <td>CATV (S01 - S05)</td> </tr> <tr> <td>CATV S1 - S10 (M1 - M10)</td> <td>CATV S11 - S20 (U1 - U10)</td> </tr> <tr> <td>CATV S21 - S41 (HYPERBAND)</td> <td></td> </tr> </table>	VHF E2 - E12	VHF H1 - H2 (ITALY)	VHF A - H (ITALY)	VHF R1 - R2	VHF R3 - R5	VHF R6 - R12	UHF E21 - E69	CATV (S01 - S05)	CATV S1 - S10 (M1 - M10)	CATV S11 - S20 (U1 - U10)	CATV S21 - S41 (HYPERBAND)	
VHF E2 - E12	VHF H1 - H2 (ITALY)												
VHF A - H (ITALY)	VHF R1 - R2												
VHF R3 - R5	VHF R6 - R12												
UHF E21 - E69	CATV (S01 - S05)												
CATV S1 - S10 (M1 - M10)	CATV S11 - S20 (U1 - U10)												
CATV S21 - S41 (HYPERBAND)													
Intermediate Frequency :													
Video	38.9 MHz, 34MHz												
Sound	32.9MHz, 33.4 MHz												
	33.16 MHz, 32.4 MHz, 40.4MHz												
Colour	34.47 MHz, 34.5 MHz, 34.65 MHz												
Video / Audio Terminals :													
AUDIO MONITOR OUT	Audio(RCA x 2) 500mV rms, 1kΩ												
AV1 IN	Video (21 pin) 1V p-p 75Ω Audio (21 pin) 500mV rms 10kΩ RGB (21 pin)												

AV1 OUT	Video (21 pin) 1V p-p 75Ω Audio (21 pin) 500mV rms 1kΩ
AV2 IN	Video (21 pin) 1V p-p 75Ω Audio (21 pin) 500mV rms 10kΩ S-Video IN Y : 1V p-p 75Ω (21 pin) C : 0.3V p-p 75Ω
AV2 OUT	Video (21 pin) 1V p-p 75Ω Audio (21 pin) 500mV rms 1kΩ Selectable Output (21 Pin)
AV3 IN	Audio (RCA x 2) 500mV rms, 10kΩ Video (RCA x 1) 1V p-p 75Ω
High Voltage :	28.5kV ± 1kV (zero beam current)

Audio Output :	
Speaker	2 x 20W (Music Power) 8Ω Impedance
Headphones	8Ω Impedance
Accessories supplied :	Remote Control 2 x R6 (UM3) Batteries

Dimensions :	
Height :	596.5mm {550mm}
Width :	778 mm {730mm}
Depth :	481.5 mm {479mm}
Net Weight :	35kg {30kg}

Specifications are subject to change without notice.
Weight and dimensions shown are approximate.

CONTENTS

- SAFETY PRECAUTIONS
- SERVICE HINTS
- SERVICE MODE
- ADJUSTMENT PROCEDURE
- SELF CHECK
- ALIGNMENT SETTINGS
- WAVEFORM PATTERN TABLE
- BLOCK DIAGRAMS
- PARTS LOCATION
- REPLACEMENT PARTS LIST
- CONDUCTOR VIEWS
- SCHEMATIC DIAGRAMS

SAFETY PRECAUTIONS

GENERAL GUIDE LINES

1. It is advisable to insert an isolation transformer in the AC supply before servicing a hot chassis.
2. When servicing, observe the original lead dress in the high voltage circuits. If a short circuit is found, replace all parts which have been overheated or damaged by the short circuit.
3. After servicing, see that all the protective devices such as insulation barriers, insulation papers, shields and isolation R-C combinations are correctly installed.
4. When the receiver is not being used for a long period of time, unplug the power cord from the AC outlet.
5. Potentials as high as 29.5kV are present when this receiver is in operation. Operation of the receiver without the rear cover involves the danger of a shock hazard from the receiver power supply. Servicing should not be attempted by anyone who is not familiar with the precautions necessary when working on high voltage equipment. Always discharge the anode of the picture tube to the chassis before handling the tube.
6. After servicing make the following leakage current checks to prevent the customer from being exposed to shock hazards.

LEAKAGE CURRENT COLD CHECK

1. Unplug the AC cord and connect a jumper between the two prongs of the plug.
2. Turn on the receiver's power switch.
3. Measure the resistance value with an ohmmeter, between the jumpered AC plug and each exposed metallic cabinet part on the receiver, such as screw heads, aerials, connectors, control shafts etc. When the exposed metallic part has a return path to the chassis the reading should be between 4M ohm and 20M ohm. When the exposed metal does not have a return path to the chassis the reading must be infinite.

LEAKAGE CURRENT HOT CHECK

1. Plug the AC cord directly into the AC outlet. Do not use an isolation transformer for this check.
2. Connect a 2kΩ 10W resistor in series with an exposed metallic part on the receiver and an earth such as a water pipe.

3. Use an AC voltmeter with high impedance to measure the potential across the resistor.
4. Check each exposed Metallic part and check the voltage at each point.
5. Reverse the AC plug at the outlet and repeat each of the above measurements.
6. The potential at any point should not exceed 1.4 Vrms. In case a measurement is outside the limits specified, there is a possibility of a shock hazard, and the receiver should be repaired and rechecked before it is returned to the customer.

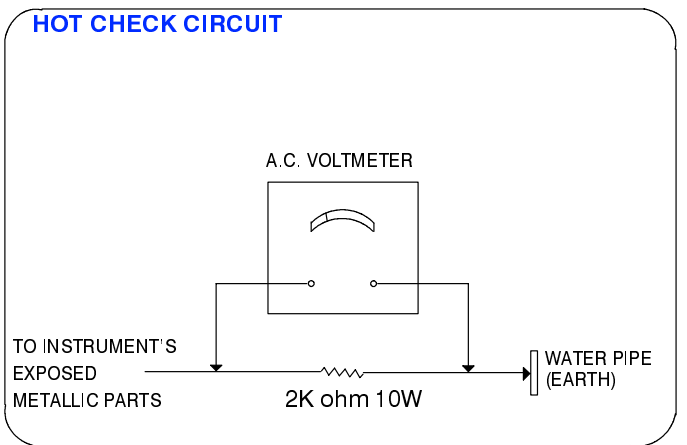

Fig.1.

X-RADIATION WARNING

1. The potential sources of X-Radiation in TV sets are the high voltage section and the picture tube.
2. When using a picture tube test jig for service ensure that the jig is capable of handling 29.5kV without causing X-Radiation.

NOTE : It is important to use an accurate periodically calibrated high voltage meter

1. Set the brightness to minimum.
2. Measure the high voltage. The meter should indicate 28.5kV ± 1kV if the meter indication is out of tolerance, immediate service and correction is required to prevent the possibility of premature component failure.
3. To prevent any X-Radiation possibility, it is essential to use the specified tube.

SERVICE HINTS

HOW TO REMOVE THE REAR COVER

1. Remove the 9 screws (A) as shown in **Fig.2./Fig.3.**

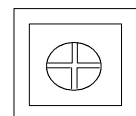
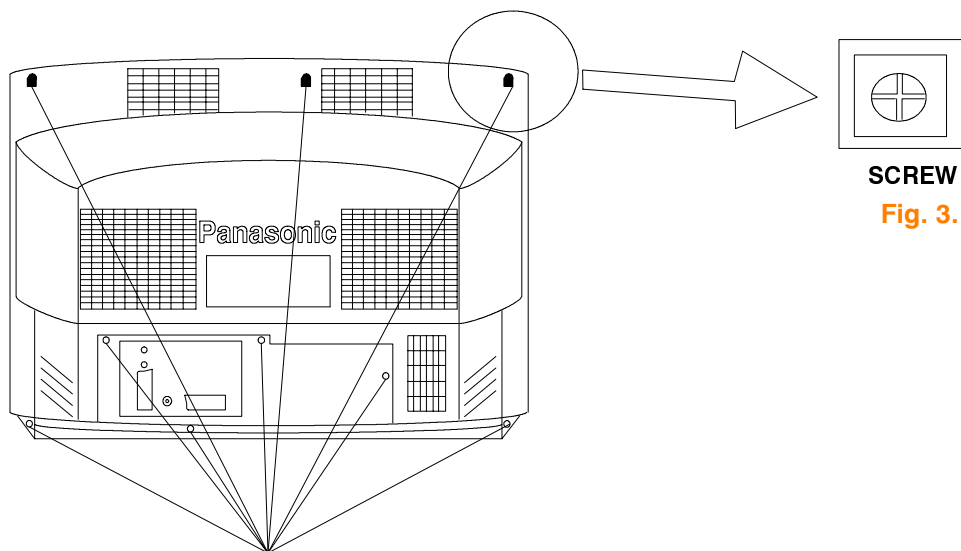

SCREW
Fig. 3.

SCREWS A
Fig. 2.

LOCATION OF CONTROLS

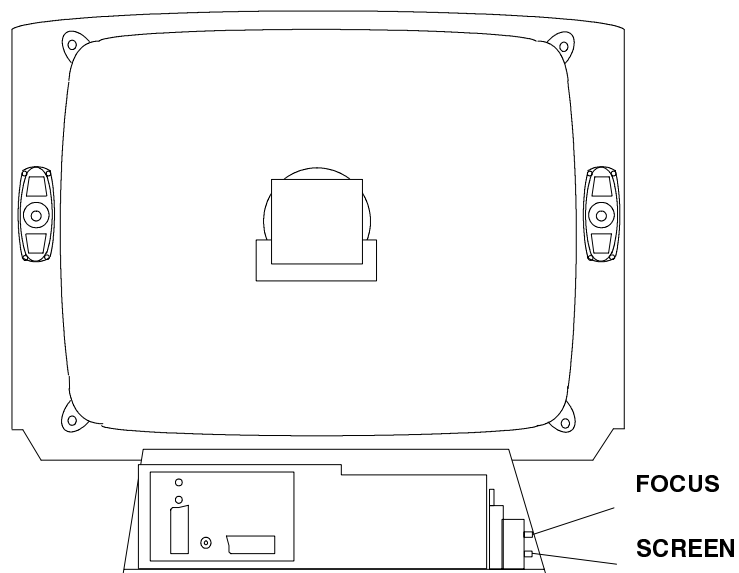

E P.C.B.
Fig. 4.

FOCUS
SCREEN

SERVICE MODE

The remote control is used for entering and storing adjustments, with the exception of cut-off adjustments which must always be done prior to service adjustment. Perform adjustments in accordance with screen display. The display on the screen also specifies the CCU variants as well as the approx. setting values. The adjustment sequence for the service mode is indicated below.

1. Set the Bass to maximum position, set the Treble to minimum position, press the Reveal button on the remote control and at the same time press the Volume down on the customer controls at the front of the TV, this will place the TV into the Service Mode.
2. Press the RED / GREEN buttons to step down / up through the functions.
3. Press the YELLOW / BLUE buttons to alter the function values.
4. Press the STORE button on the preset panel after each adjustment has been made to store the required values.
5. To exit the Service Mode press the Normalisation button.

NOTE: This TV also has the option of using a Memory Pack which enables you to copy the preset TV channels and analogue levels into the Memory Pack and then upload them onto another EURO-3H TV set.

USING THE MEMORY PACK

TV to Memory Pack process

1. Plug the memory pack into the lower of the two 21 pin terminals at the back of the TV and switch the TV on. If the TV has only one 21 pin connector then this will be able to accept the memory pack.
2. Go into the Service Mode as explained above. The screen will show:-

Program
External >> TV

3. Press the blue button on the remote control. The screen will show:-

Program
TV >> External

4. Press the STORE button on the TV. The screen will show:-

Storing

5. All the tuning information stored inside the TV will now be transferred to the Memory Pack. This process will take 2-3 minutes to complete and when finished the screen will show:-

OK!

Memory Pack to TV Process

1. Plug the memory pack into the lower of the two 21 pin terminals at the back of the TV and switch the TV on. If the TV has only one 21 pin connector then this will be able to accept the memory pack.
2. Go into the Service Mode as explained above. The screen will show:-

Program
External >> TV

3. Press the STORE button on the TV. The screen will show:-

Loading

4. All the tuning information stored inside the Memory Pack will now be transferred to the TV. This process will take 2-3 minutes to complete and when finished the screen will show:-

OK!

5. The tuning information from the Memory Pack has now been copied into the TV
6. To exit from the Service Mode switch off the TV.
7. The process has now been completed and the Memory Pack can now be removed.

ERRORS

If an error occurs while using the Memory Pack the TV will detect this and the screen will show:-

Program
Error!

If this happens then switch off the TV and repeat the process that was being used. If the errors continue to occur then check the connectors between the TV and the memory pack and check the 9V battery inside the memory pack.

ADJUSTMENT PROCEDURE

Item/Preparation	Adjustments
Supply Voltage Check 1. Receive a standard test pattern 2. Set the controls: Brightness Minimum Contrast Minimum Volume Minimum	1. Confirm the following voltages. E PCB D PCB U5B 5 ± 0.5V U5A 5.1 ± 0.12V U8A 8 ± 0.5V U5SB 5 ± 0.25V U9 9 ± 0.5V TP1 15 ± 0.7V U12 11.8 ± 0.5V U16 18.2 ± 0.8V U22 22.5 ± 1V U38 39 ± 1V TP2 54 ± 2.5V U150 150 ± 1V U200 200 ± 10V

SELF CHECK

Self check is used to automatically check the Bus lines and Hexadecimal code of the TV set.
 To enter the Self Check mode press Function down button, on the Preset Panel, at the same time pressing the Status button, on the Remote Control, and the screen will show:-
 When exiting Self Check the customer settings will return to factory setup.

0	—	ok	Test Byte
1	—	ok	Lst Power
2	—	ok	U5 Det
3	—	ok	Protector
4	—	ok	Not Used
5	—	ok	Not Used
6	—	ok	Not Used
7	—	ok	Not Used

8	—	ok	Col Decoder (M)
9	—	ok	Clock generator
10	—	ok	V - Processor
11	—	ok	DFU
12	—	ok	Display Processor
13	—	ok	RGB Processor
14	—	ok	Deflection IC
15	—	ok	MSP

Hex codes

16	—	—	Col Decoder (P)
17	—	—	Q - PIP
18	—	ok	Not Used
19	—	ok	Not Used
20	—	ok	EAROM
21	—	ok	Audio Matrix
22	—	ok	Video Matrix
23	—	ok	Tuner

TX-28/25XD60P

09
73
A4
BF
BB
BF
33

TX-28/25XD60S

09
73
A4
BC
B3
BB
33

If the CCU ports have been checked and found to be incorrect or not located then "—" will appear in place of "OK".

ALIGNMENT SETTINGS

(The figures used below are nominal and used for representative purposes only)

Alignment Function		Settings / Special features
Vertical amplitude	V-AMP 038	Optimum setting
Vertical linearity	V-LIN 022	
V-Pos.	V-POS 005	Optimum setting
Horizontal amplitude	H-AMP 043	Optimum setting
Horizontal position	H-POS 035	
EW-amplitude	E/W-AMP 1 020	Optimum setting
EW-amplitude	E/W-AMP 2 015	Optimum setting
Trapezium-comp	TRAPEZ-1 004	Optimum setting
Vert. DC.	VERT. D.C. 008	Not to be adjusted.
Text Position	TEXT POSITION 060	Optimum setting
Cutoff	---	Enter Service Mode and step through to Cutoff, connect an oscilloscope to the Blue Cathode and adjust the screen VR of the FBT to get $150 \pm 5V$ at the base of the Cutoff pulse.
Cutoff RGB	CUTOFF RGB 032 032 032	Press the GREEN button to step through these settings. Adjust for optimum.
White RGB	WHITE RGB 032 032 032	Press the GREEN button to step through these settings. Adjust for optimum.
Sub Brightness	SUB BRIGHT 000	Optimum setting

WAVEFORM PATTERN TABLE

NOTE: All waveforms have been taken using a standard colour bar pattern

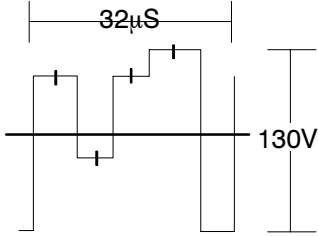
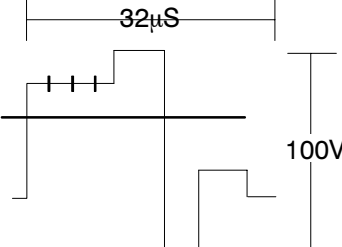
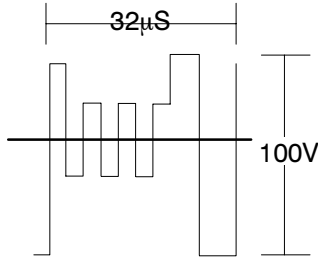
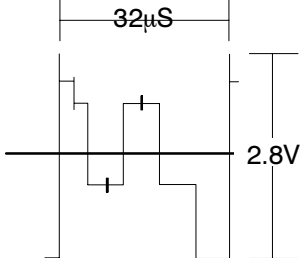
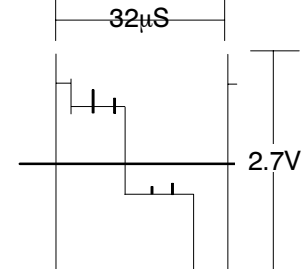
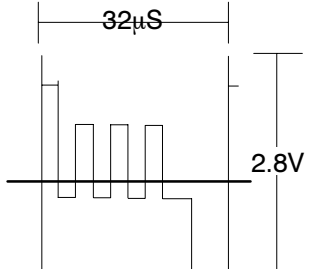
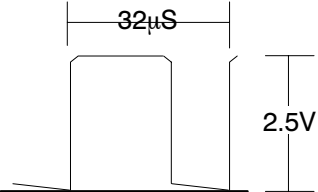
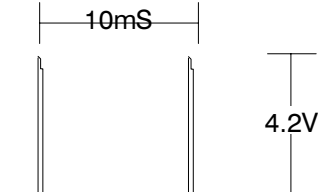
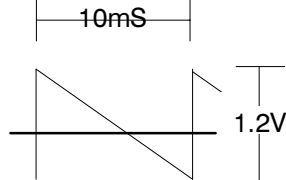
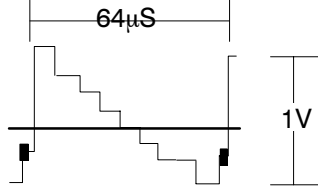
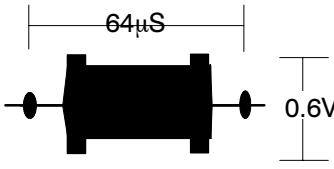
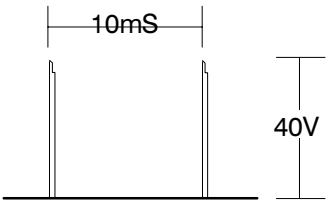
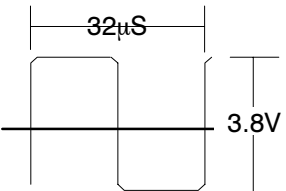
<p>RED DRIVE TPY1</p> 	<p>GREEN DRIVE TPY2</p> 	<p>BLUE DRIVE TPY3</p> 
<p>RED OUTPUT IC 603 PIN 24</p> 	<p>GREEN OUTPUT IC 603 PIN 22</p> 	<p>BLUE OUTPUT IC 603 PIN 20</p> 
<p>HORIZONTAL SYNC IC 3501 PIN 4</p> 	<p>VERTICAL SYNC IC 3501 PIN 3</p> 	<p>VERT OUTPUT IC (INPUT) IC 451 PIN 1</p> 
<p>LUMINANCE IN IC601 PIN 26</p> 	<p>CHROMINANCE IN IC601 PIN 25</p> 	<p>VERTICAL OUTPUT (DRIVE) IC 451 PIN 9</p> 
<p>HORIZONTAL OUTPUT IC401 PIN 20</p> 		

VIDEO AND AUDIO SIGNAL PROCESSING BLOCK DIAGRAM

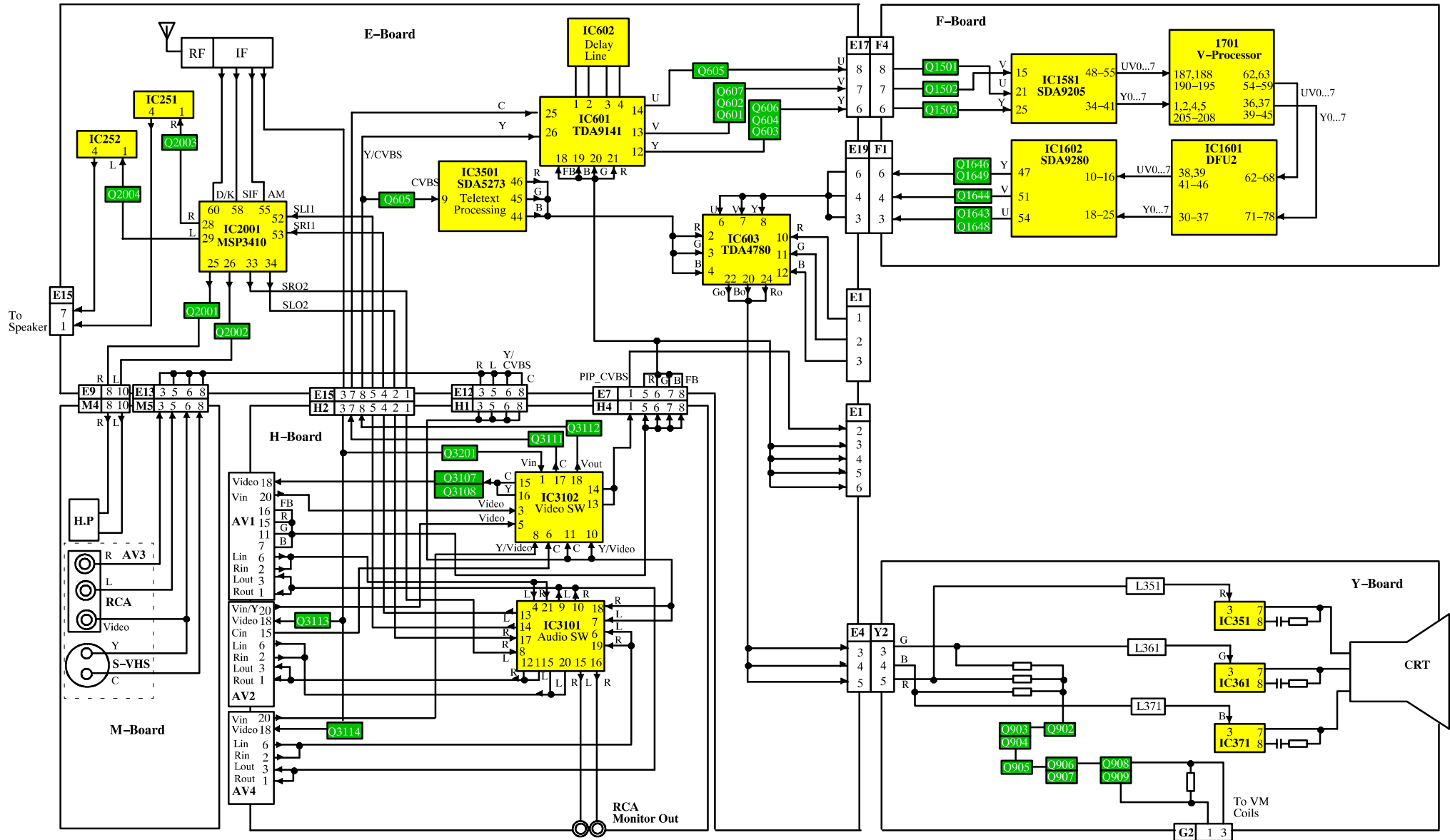

CONTROL BLOCK DIAGRAM

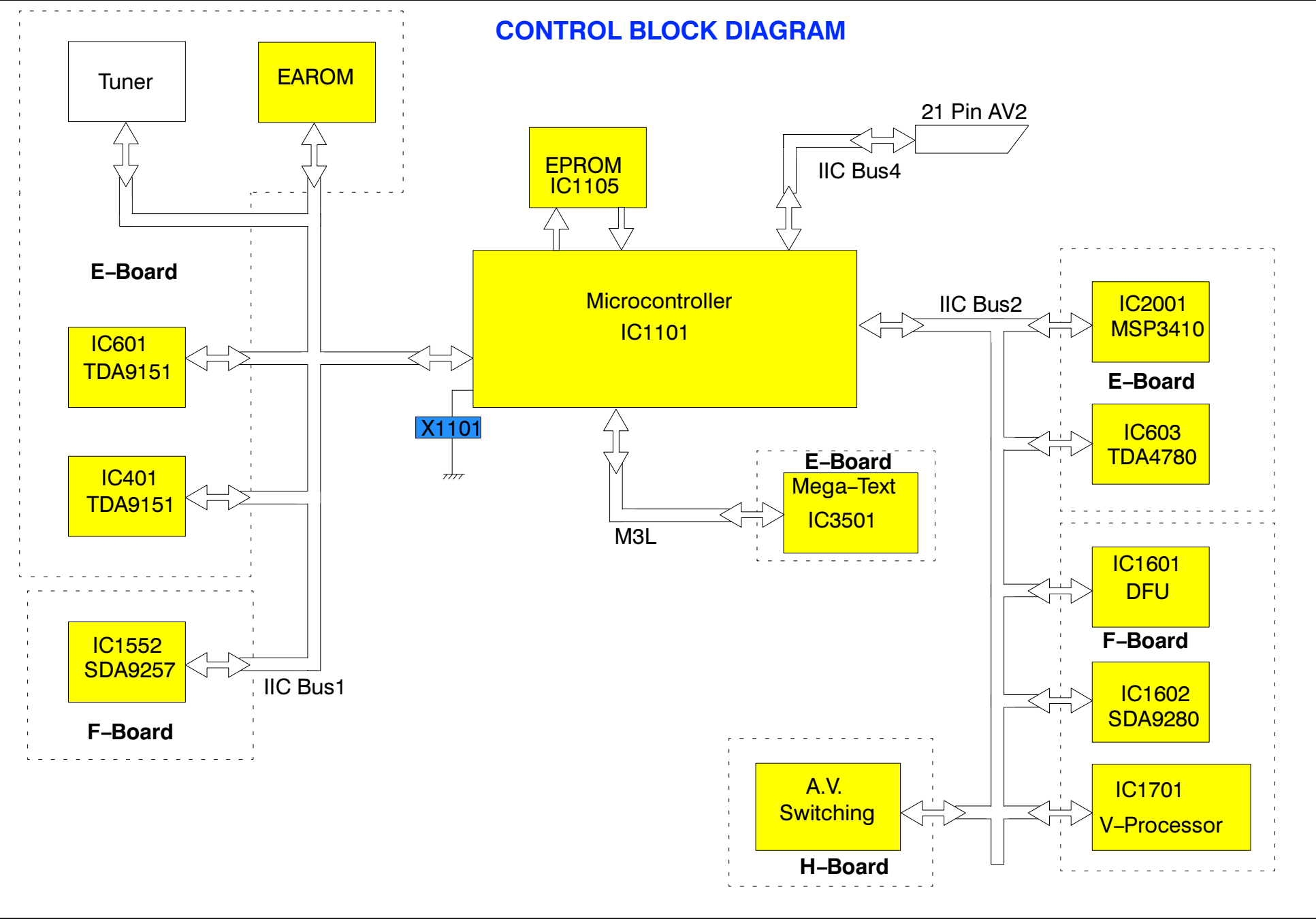

PARTS LOCATION

NOTE :

The numbers on the exploded view below refer to the miscellaneous section of the Replacement Parts List.

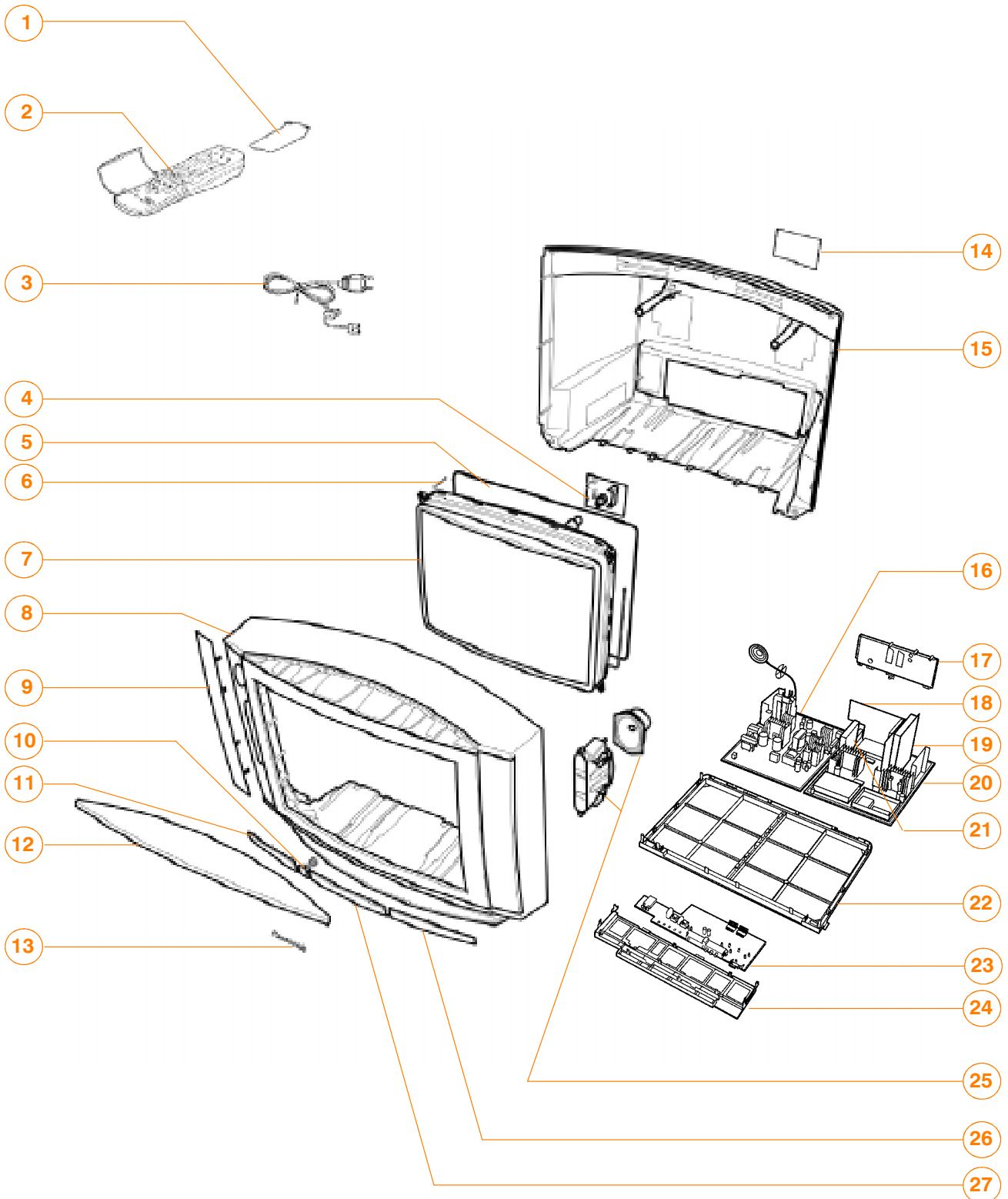

REPLACEMENT PARTS LIST

Important Safety Notice

Components identified by Δ mark have special characteristics important for safety.
When replacing any of these components, use only manufacturer's specified parts.

COMMON PARTS FOR MODELS TX-28XD60P, /A, /B AND TX-25XD60P, /A, /B AND TX-28XD60S, /A, /B AND TX-25XD60S, /A, /B

Ref No.	Part No.	Description
MISCELLANEOUS COMPONENTS		
1)	UR51EC780	BATTERY COVER (REMOTE)
2)	EUR51923	REMOTE CONTROL
3)	TSX8E022	POWER CORD Δ
4)	*****	SEE DIFFERENCE LIST
5)	*****	SEE DIFFERENCE LIST
6)	VP17005-32	CRT FIXING SCREW
7)	*****	SEE DIFFERENCE LIST
8)	*****	SEE DIFFERENCE LIST
9)	*****	SEE DIFFERENCE LIST
10))	*****	SEE DIFFERENCE LIST
11)	*****	SEE DIFFERENCE LIST
12)	*****	SEE DIFFERENCE LIST
13)	TBM8E1728	PANASONIC BADGE
14)	*****	SEE DIFFERENCE LIST
15)	*****	SEE DIFFERENCE LIST
16)	*****	SEE DIFFERENCE LIST
17)	TKP8E1166	REAR AV COVER
18)	TNPA0293AB	H P.C.B. Δ
19)	TNPA0756AA	F P.C.B. Δ
20)	*****	SEE DIFFERENCE LIST
21)	TNPA0317AB	B P.C.B. Δ
22)	TMX8E014	CHASSIS FRAME
23)	TNPA0766AA	M P.C.B. Δ
24)	TMX8E015	PCB SUPPORT BRACKET
25)	EAG1216A2	SPEAKER
26)	*****	SEE DIFFERENCE LIST
27)	*****	SEE DIFFERENCE LIST
	TBM8E1616	PRESET LABEL
	TBM8E1675	REAR AV LABEL
	TEK6940	LID CATCHER
	TES8E015	POWER BUTTON SPRING
	ENV57D03G3	TUNER Δ
	TLT100K991R	COIL
	TMW8E020-1	LED HOLDER
	TMW8E025	CONTROL BRACKET
	UM-3DJ-2P	BATTERY SET
	F9-4-220	RELAY
	TES4537	SPRING
	TUX8E033	HEAT SINK
	ERC12GK825	SOLID 0.5W 10% 8M2 Ω
	ERDS1TJ6R8	CARBON 0.5W 5% 6R8 Ω
	832AG11D-ESL	I.C.SOCKET
	PCS-068A-1	68 PIN I.C.SOCKET
INTEGRATED CIRCUITS		
IC101	TDA9814TV3	VIF
IC251	TDA2030AV	AUDIO AMPLIFIER
IC252	TDA2030AV	AUDIO AMPLIFIER
IC351	TDA6111	RGB OUTPUT
IC361	TDA6111	RGB OUTPUT
IC371	TDA6111	RGB OUTPUT
IC401	TDA9151-B	DEFLECTION CONTROL
IC451	TDA8350Q/N5	VERTICAL OUTPUT
IC601	TDA9143-N1	COLOUR DECODER
IC602	TDA4665-V4	DELAY LINE
IC603	TDA4780/V4	RGB VIDEO PROCESSOR

Ref No.	Part No.	Description
IC801	AN8029	POWER SUPPLY
IC845	SE140N	ERROR AMPLIFIER
IC851	TL431ACLPM	REGULATOR
IC852	TL431ACLPM	REGULATOR
IC1051	RPM-637CBRL	LED RECEIVER
IC1101	SDA30C164-2	MICRO PROCESSOR
IC1102	S-80745AL-Z	RESET
IC1103	MN1280R	RESET
IC1551	SN74F04DR	CLOCK
IC1552	SDA9257	CLOCK GENERATOR
IC1581	SDA9205-2GEG	A/D CONVERTER
IC1601	UPD93213GF	DFU
IC1602	SDA9280B22GE	VIDEO PROCESSOR
IC1701	SDA9255EGEG	VIDEO PROCESSOR
IC3101	TEA6420	AUDIO SWITCH
IC3102	TEA6415C	VIDEO SWITCH
IC3501	SDA5273S/134	MEGA TEXT
IC3502	M514256B70RS	DRAM
IC3801	AN7808LB	8V REGULATOR
IC3803	AN7805LB	5V REGULATOR
IC3804	AN7809FLB	9V REGULATOR
IC3805	AN78L08TA	8V REGULATOR
CAPACITORS		
C002	ECUV1H102JCX	S.M.CAP 50V 1nF
C003	ECA1HM101GB	ELECT 50V 100 μ F
C004	ECUV1H102JCX	S.M.CAP 50V 1nF
C005	ECUV1H102JCX	S.M.CAP 50V 1nF
C006	ECUV1H102JCX	S.M.CAP 50V 1nF
C007	ECUV1H102JCX	S.M.CAP 50V 1nF
C009	ECA1HMR22GB	ELECT 50V 0.22 μ F
C010	ECUV1H102KBX	S.M.CAP 50V 1nF
C014	ECUV1H103ZFX	S.M.CAP 50V 10nF
C015	ECUV1H390JCX	S.M.CAP 50V 39pF
C016	ECUV1H390JCX	S.M.CAP 50V 39pF
C017	ECA1CM470GB	ELECT 16V 47 μ F
C019	ECUV1H561JCX	S.M.CAP 50V 560pF
C020	ECUV1H103ZFX	S.M.CAP 50V 10nF
C022	ECUV1H103ZFX	S.M.CAP 50V 10nF
C023	ECUV1H681JCX	S.M.CAP 50V 680pF
C024	ECUV1H103ZFX	S.M.CAP 50V 10nF
C025	ECUV1H101JCX	S.M.CAP 50V 100pF
C026	ECUV1H681JCX	S.M.CAP 50V 680pF
C101	ECUV1H104ZFX	S.M.CAP 50V 100nF
C106	ECUV1H104ZFX	S.M.CAP 50V 100nF
C108	ECUV1H104ZFX	S.M.CAP 50V 100nF
C109	ECUV1H104ZFX	S.M.CAP 50V 100nF
C111	ECUV1H103ZFX	S.M.CAP 50V 10nF
C113	ECUV1H393KBX	S.M.CAP 50V 39nF
C115	ECUV1H104ZFX	S.M.CAP 50V 100nF
C116	ECUV1H030CPX	S.M.CAP 50V 30pF
C117	ECUV1H070DTX	S.M.CAP 50V 70pF
C118	ECEA1CKA100	ELECT 16V 10 μ F
C120	ECEA1HKA2R2	ELECT 50V 2.2 μ F
C121	ECEA1HKA2R2	ELECT 50V 2.2 μ F
C122	ECUV1C105ZFX	S.M.CAP 16V 1000nF
C123	ECEA1HKA2R2	ELECT 50V 2.2 μ F
C124	ECUV1H471JCX	S.M.CAP 50V 470pF
C125	ECUV1H104ZFX	S.M.CAP 50V 100nF
C126	ECUV1H104ZFX	S.M.CAP 50V 100nF

Ref No.	Part No.	Description		
C127	ECEA1CKA100	ELECT	16V	10µF
C128	ECUV1H102KBX	S.M.CAP	50V	1nF
C129	ECEA1CKA100	ELECT	16V	10µF
C130	ECUV1H104ZFX	S.M.CAP	50V	100nF
C131	ECUV1H102KBX	S.M.CAP	50V	1nF
C132	ECUV1H102KBX	S.M.CAP	50V	1nF
C133	ECUV1H102KBX	S.M.CAP	50V	1nF
C134	ECUV1H104ZFX	S.M.CAP	50V	100nF
C135	ECEA1CKA100	ELECT	16V	10µF
C136	ECUV1H104ZFX	S.M.CAP	50V	100nF
C137	ECUV1H100DCX	S.M.CAP	50V	10pF
C138	ECUV1H151JCX	S.M.CAP	50V	150pF
C139	ECUV1H104ZFX	S.M.CAP	50V	100nF
C140	ECUV1H151JCX	S.M.CAP	50V	150pF
C142	ECUV1H100DCX	S.M.CAP	50V	10pF
C143	ECUV1H220JCX	S.M.CAP	50V	22pF
C144	ECUV1H151JCX	S.M.CAP	50V	150pF
C145	ECUV1H151JCX	S.M.CAP	50V	150pF
C146	ECUV1H120JCX	S.M.CAP	50V	12pF
C148	ECUV1H103ZFX	S.M.CAP	50V	10nF
C150	ECEA1CKA100	ELECT	16V	10µF
C151	ECUV1H104ZFX	S.M.CAP	50V	100nF
C152	ECUV1H104ZFX	S.M.CAP	50V	100nF
C153	ECUV1H120JCX	S.M.CAP	50V	12pF
C158	ECUV1H103ZFX	S.M.CAP	50V	10nF
C159	ECUV1H080CCX	S.M.CAP	50V	80pF
C251	ECQM1H474J	FILM	50V	470nF
C252	ECUV1H222JCX	S.M.CAP	50V	2.2nF
C254	ECUV1H393KBX	S.M.CAP	50V	39nF
C255	ECEA1CN100	ELECT	16V	10µF
C256	ECA1HM330B	ELECT	50V	33µF
C257	ECA1HM100GB	ELECT	50V	10µF
C258	ECQM1H474J	FILM	50V	470nF
C259	ECUV1H222JCX	S.M.CAP	50V	2.2nF
C261	ECUV1H393KBX	S.M.CAP	50V	39nF
C262	ECEA1CN100	ELECT	16V	10µF
C263	ECA1HM330B	ELECT	50V	33µF
C264	ECA1HM100GB	ELECT	50V	10µF
C267	ECUV1H103ZFX	S.M.CAP	50V	10nF
C268	ECUV1H223ZFX	S.M.CAP	50V	22nF
C269	ECA1EM222GB	ELECT	25V	2.2µF
C270	ECA1EM222GB	ELECT	25V	2.2µF
C271	ECA1HM010GB	ELECT	50V	1µF
C272	ECA1HM010GB	ELECT	50V	1µF
C273	ECA1HM010GB	ELECT	50V	1µF
C274	ECA1HM010GB	ELECT	50V	1µF
C275	ECUV1C184KBX	S.M.CAP	16V	0.18µF
C276	ECUV1C184KBX	S.M.CAP	16V	0.18µF
C277	ECEA1HU471	ELECT	50V	470µF
C280	ECUV1H562KBX	S.M.CAP	50V	5.6nF
C281	ECUV1H561JCX	S.M.CAP	50V	560pF
C282	ECUV1H561JCX	S.M.CAP	50V	560pF
C283	ECUV1H561JCX	S.M.CAP	50V	560pF
C402	ECUV1H104ZFX	S.M.CAP	50V	100nF
C403	ECA1AM332E	ELECT	10V	3.3µF
C404	ECUV1H104ZFX	S.M.CAP	50V	100nF
C405	ECUV1H104ZFX	S.M.CAP	50V	100nF
C406	ECUV1H471JCX	S.M.CAP	50V	470pF
C409	ECUV1H101JCX	S.M.CAP	50V	100pF
C413	ECUV1H561KBX	S.M.CAP	50V	560pF
C451	ECUV1H104ZFX	S.M.CAP	50V	100nF
C452	ECA1EM332E	ELECT	25V	3.3µF
C453	ECA2CM100B	ELECT	160V	10µF
C455	ECA1HEN100B	ELECT	50V	10µF
C456	ECQV1104JZ3	FILM	100V	100nF
C457	ECUV1H102JCX	S.M.CAP	50V	1nF
C462	ECKC3A471J	CERAMIC	1KV	470pF
C463	ECUV1H102KBX	S.M.CAP	50V	1nF
C464	ECKC1H102J	CERAMIC	50V	1000pF
C501	ECQM1H224J	FILM	50V	220nF
C502	ECQM2683JZ	FILM	250V	68nF
C503	ECKC2H102J	CERAMIC	500V	1nF

Ref No.	Part No.	Description		
C504	ECQB1H223K	FILM	50V	22nF
C506	ECKC2H102J	CERAMIC	500V	1nF
C552	ECWH15H392J	FILM	1500V	3.9nF
C553	ECQP1104JZW	FILM	100V	0.10µF
C555	ECWH15H472J	FILM	1500V	4700µF
C556	ECEA2CNR47SB	ELECT	160V	R47µF
C557	ECKC2H331J	CERAMIC	500V	330pF
C558	ECA2EM330B	ELECT	250V	33µF
C559	ECKC2H101J	CERAMIC	500V	100pF
C560	ECA1EM332E	ELECT	25V	3.3µF
C561	ECKC2H561J	CERAMIC	500V	560pF
C562	ECA1JM330B	ELECT	63V	33µF
C563	ECWF2564JBK	FILM	200V	0.56µF
C564	ECKC1H472J	CERAMIC	50V	4.7nF
C565	ECQP1823JZW	FILM	100V	82nF
C571	ECQV1H105JZ	FILM	50V	1µF
C572	ECWH15H472J	FILM	1500V	4700µF
C573	ECQF4153JZH	FILM	400V	15nF
C574	ECWF4684JBB	FILM	400V	0.68µF
C575	ECWF4684JBB	FILM	400V	0.68µF
C581	ECQF4123JZH	FILM	400V	12nF
C584	ECKC3D391J	CERAMIC	2KV	390pF
C585	ECKC3A471J	CERAMIC	1KV	470pF
C586	ECKC1H103JB	CERAMIC	50V	10nF
C588	ECKC1H471J	CERAMIC	50V	470pF
C601	ECUV1H104ZFX	S.M.CAP	50V	100nF
C602	ECUV1H104ZFX	S.M.CAP	50V	100nF
C603	ECUV1H104ZFX	S.M.CAP	50V	100nF
C604	ECUV1H104ZFX	S.M.CAP	50V	100nF
C605	ECUV1H104ZFX	S.M.CAP	50V	100nF
C606	ECUV1H104ZFX	S.M.CAP	50V	100nF
C608	ECUV1H104ZFX	S.M.CAP	50V	100nF
C609	ECUV1H180JCX	S.M.CAP	50V	18pF
C610	ECUV1H150JCX	S.M.CAP	50V	15pF
C611	ECUV1H104ZFX	S.M.CAP	50V	100nF
C612	ECUV1H332ZFX	S.M.CAP	50V	3.3nF
C613	ECUV1C474ZFX	S.M.CAP	16V	0.47µF
C614	ECUV1H332ZFX	S.M.CAP	50V	3.3nF
C615	ECUV1H104ZFX	S.M.CAP	50V	100nF
C616	ECUV1H104ZFX	S.M.CAP	50V	100nF
C617	ECA1CM220GB	ELECT	16V	22µF
C618	ECUV1H104ZFX	S.M.CAP	50V	100nF
C619	ECUV1H104ZFX	S.M.CAP	50V	100nF
C620	ECUV1H104ZFX	S.M.CAP	50V	100nF
C621	ECUV1H104ZFX	S.M.CAP	50V	100nF
C622	ECUV1H104ZFX	S.M.CAP	50V	100nF
C623	ECUV1H103ZFX	S.M.CAP	50V	10nF
C624	ECUV1H103ZFX	S.M.CAP	50V	10nF
C625	ECUV1H103ZFX	S.M.CAP	50V	10nF
C626	ECUV1H103ZFX	S.M.CAP	50V	10nF
C627	ECUV1H103ZFX	S.M.CAP	50V	10nF
C628	ECUV1H103ZFX	S.M.CAP	50V	10nF
C629	ECUV1H103ZFX	S.M.CAP	50V	10nF
C630	ECUV1H103ZFX	S.M.CAP	50V	10nF
C631	ECUV1H103ZFX	S.M.CAP	50V	10nF
C632	ECUV1H103ZFX	S.M.CAP	50V	10nF
C633	ECUV1H470JCX	S.M.CAP	50V	47pF
C634	ECA1CM221GB	ELECT	16V	220µF
C635	ECA1HM220GB	ELECT	50V	22µF
C636	ECA1HM010GB	ELECT	50V	1µF
C637	ECQM1H224J	FILM	50V	220nF
C638	ECA1HM010GB	ELECT	50V	1µF
C639	ECQM1H224J	FILM	50V	220nF
C640	ECQM1H224J	FILM	50V	220nF
C641	ECQM1H224J	FILM	50V	220nF
C642	ECA1AM470GB	ELECT	10V	47µF
C643	ECUV1H104ZFX	S.M.CAP	50V	100nF
C644	ECA1CM470GB	ELECT	16V	47µF
C645	ECUV1H104ZFX	S.M.CAP	50V	100nF
C646	ECUV1H104ZFX	S.M.CAP	50V	100nF
C647	ECEA1CN470	ELECT	16V	47µF

Ref No.	Part No.	Description		
C648	ECEA1CN470	ELECT	16V 47µF	
C651	ECUV1H820JCX	S.M.CAP	50V 82pF	
C654	ECUV1H393KBX	S.M.CAP	50V 39nF	
C655	ECUV1E563KBX	S.M.CAP	25V 56nF	
C657	ECUV1C474ZFX	S.M.CAP	16V 0.47µF	
C659	ECUV1H821KBX	S.M.CAP	50V 820pF	
C661	ECUV1H103ZFX	S.M.CAP	50V 10nF	
C662	ECUV1H470JCX	S.M.CAP	50V 47pF	
C663	ECUV1H150JCX	S.M.CAP	50V 15pF	
C664	ECUV1H103ZFX	S.M.CAP	50V 10nF	
C703	ECUV1C224KBX	S.M.CAP	16V 220nF	
C752	ECKC2H103J	CERAMIC	50V 10nF	△
C803	ECQE2A474MWB	FILM	100V 0.47µF	
C804	ECQU2A154MN	FILM	250V 150nF	
C806	ECQE6104K	FILM	600V 100nF	△
C807	ECQB1H473K	FILM	50V 47nF	
C808	ECQB1H333J	FILM	50V 33nF	
C810	222233510154	CAPACITOR	0.15µF	
C811	ECQB1H104J	FILM	50V 100nF	
C812	ECQB1H562K	FILM	50V 5.6nF	
C813	ECKC2H472J	CERAMIC	500V 4.7nF	△
C814	ECKC2H472J	CERAMIC	500V 4.7nF	△
C815	ECA1CM331B	ELECT	16V 330µF	
C816	ECQB1H122J	FILM	50V 1.2nF	
C817	ECKC2H472J	CERAMIC	500V 4.7nF	△
C818	ECKC2H472J	CERAMIC	500V 4.7nF	△
C819	ECOS2GG181NG	ELECT	400V 180µF	△
C820	ECOS2GG181NG	ELECT	400V 180µF	△
C821	ECQB1H222J	FILM	50V 2200pF	
C822	ECKC3D471JB	CERAMIC	2KV 470pF	△
C823	EEUFA1V221B	CERAMIC	35V 220pF	
C824	ECQB1H121KF3	FILM	50V 120pF	
C826	ECQB1H473K	FILM	50V 47nF	
C827	ECKCNS332J	CERAMIC	1K2V 3.3nF	△
C830	ECQE4105JFW	FILM	400V 1µF	
C831	ECKC3D471JB	CERAMIC	2KV 470pF	△
C833	ECQB1H682K	FILM	50V 6.8nF	
C835	ECQB1H332K	FILM	50V 3.3nF	
C848	ECKC2H471J	CERAMIC	500V 470pF	△
C849	ECKC2H471J	CERAMIC	500V 470pF	△
C851	ECQM1H104J	FILM	50V 100nF	
C852	ECKC3D222JB	CERAMIC	2KV 2200pF	△
C853	ECA1CM471GB	ELECT	16V 470µF	
C854	ECA1EM471GB	ELECT	25V 470µF	
C855	ECEA1HU102	ELECT	50V 1000µF	
C856	ECEA1HU471	ELECT	50V 470µF	
C857	ECA1EM471GB	ELECT	25V 470µF	
C858	ECOS2EA271BB	ELECT	250V 270pF	
C859	ECKC2H471J	CERAMIC	500V 470pF	△
C861	ECOS2EA221AB	ELECT	250V 220µF	
C863	ECA1EM222GB	ELECT	25V 2.2µF	
C864	ECA0JM102GB	ELECT	6.3V 1µF	
C866	ECA1HM101GB	ELECT	50V 100µF	
C867	ECA1CM222GB	ELECT	16V 2200µF	
C868	ECA1CM100GB	ELECT	16V 10µF	
C871	ECA0JM102GB	ELECT	6.3V 1µF	
C872	ECA1CM222GB	ELECT	16V 2200µF	
C874	ECKC1H102J	CERAMIC	50V 1000pF	
C1051	ECKC1H101J	CERAMIC	50V 100pF	
C1052	ECA1VM470B	ELECT	35V 47µF	
C1053	ECKC1H103JB	CERAMIC	50V 10nF	
C1102	ECUV1H104ZFX	S.M.CAP	50V 100nF	
C1103	ECUV1H104ZFX	S.M.CAP	50V 100nF	
C1104	ECA0JM101G	ELECT	6.3V 100µF	
C1105	ECUV1H330JCX	S.M.CAP	50V 33pF	
C1106	ECUV1H330JCX	S.M.CAP	50V 33pF	
C1107	ECUV1H391JCX	S.M.CAP	50V 390pF	
C1108	ECUV1H103ZFX	S.M.CAP	50V 10nF	
C1109	ECUV1H472KBX	S.M.CAP	50V 4.7nF	
C1110	ECUV1H104ZFX	S.M.CAP	50V 100nF	
C1111	ECUV1H101JCX	S.M.CAP	50V 100pF	

Ref No.	Part No.	Description		
C1112	ECUV1H103ZFX	S.M.CAP	50V 10nF	
C1114	ECUV1H102JCX	S.M.CAP	50V 1nF	
C1115	ECUV1H102JCX	S.M.CAP	50V 1nF	
C1126	ECUV1H104ZFX	S.M.CAP	50V 100nF	
C1127	ECUV1H104ZFX	S.M.CAP	50V 100nF	
C1129	ECA1AM470GB	ELECT	10V 47µF	
C1130	ECUV1H104ZFX	S.M.CAP	50V 100nF	
C1131	ECUV1H101JCX	S.M.CAP	50V 100pF	
C1133	ECUV1C184KBX	S.M.CAP	16V 0.18µF	
C1134	ECUV1H103KBX	S.M.CAP	50V 10nF	
C1135	ECUV1H103ZFX	S.M.CAP	50V 10nF	
C1136	ECUV1H101JCX	S.M.CAP	50V 100pF	
C1137	ECUV1H102KBX	S.M.CAP	50V 1nF	
C1138	ECUV1H104ZFX	S.M.CAP	50V 100nF	
C1304	ECUV1H103ZFX	S.M.CAP	50V 10nF	
C1305	ECA1HM101GB	ELECT	50V 100µF	
C1317	ECUV1H104ZFX	S.M.CAP	50V 100nF	
C1321	ECUV1H104ZFX	S.M.CAP	50V 100nF	
C1322	ECUV1H101JCX	S.M.CAP	50V 100pF	
C1327	ECUV1H104ZFX	S.M.CAP	50V 100nF	
C1508	ECUV1H103KBX	S.M.CAP	50V 10nF	
C1509	ECA1VM470B	ELECT	35V 47µF	
C1518	ECA1HM101GB	ELECT	50V 100µF	
C1519	ECA1HM101GB	ELECT	50V 100µF	
C1520	ECA1HM101GB	ELECT	50V 100µF	
C1524	ERJ6GEY0R00	S.M.CARB	0.1W 5%	Ω
C1525	ECUV1H221JCX	S.M.CAP	50V 220pF	
C1529	ERJ6GEY0R00	S.M.CARB	0.1W 5%	Ω
C1531	ECUV1H221JCX	S.M.CAP	50V 220pF	
C1532	ECUV1H680JCX	S.M.CAP	50V 68pF	
C1533	ECUV1H560JCX	S.M.CAP	50V 56pF	
C1534	ECUV1H271JCX	S.M.CAP	50V 270pF	
C1537	ECA0JM102GB	ELECT	6.3V 1µF	
C1538	ECUV1H151JCX	S.M.CAP	50V 150pF	
C1539	ECUV1H152JCX	S.M.CAP	50V 1.5pF	
C1540	ECUV1H151JCX	S.M.CAP	50V 150pF	
C1541	ECUV1H152JCX	S.M.CAP	50V 1.5pF	
C1542	ECUV1H101JCX	S.M.CAP	50V 100pF	
C1543	ECUV1H391JCX	S.M.CAP	50V 390pF	
C1552	ECUV1H104ZFX	S.M.CAP	50V 100nF	
C1553	ECUV1H270JCX	S.M.CAP	50V 27pF	
C1554	ECUV1H104ZFX	S.M.CAP	50V 100nF	
C1555	ECA0JM331GB	ELECT	6.3V 330µF	
C1556	ECUV1H270JCX	S.M.CAP	50V 27pF	
C1557	ECUV1H270JCX	S.M.CAP	50V 27pF	
C1558	ECUV1H104ZFX	S.M.CAP	50V 100nF	
C1559	ECUV1H103KBX	S.M.CAP	50V 10nF	
C1560	ECUV1H103KBX	S.M.CAP	50V 10nF	
C1561	ECUV1H104ZFX	S.M.CAP	50V 100nF	
C1562	ECA0JM331GB	ELECT	6.3V 330µF	
C1564	ECUV1H104ZFX	S.M.CAP	50V 100nF	
C1575	ECUV1H104ZFX	S.M.CAP	50V 100nF	
C1576	ECUV1H104ZFX	S.M.CAP	50V 100nF	
C1577	ECA1HM101GB	ELECT	50V 100µF	
C1579	ECUV1H104ZFX	S.M.CAP	50V 100nF	
C1580	ECUV1H104ZFX	S.M.CAP	50V 100nF	
C1583	ECUV1H104ZFX	S.M.CAP	50V 100nF	
C1584	ECUV1H104ZFX	S.M.CAP	50V 100nF	
C1585	ECUV1H104ZFX	S.M.CAP	50V 100nF	
C1586	ECUV1H104ZFX	S.M.CAP	50V 100nF	
C1588	ECA1VM470B	ELECT	35V 47µF	
C1590	ECUV1H104ZFX	S.M.CAP	50V 100nF	
C1591	ECUV1H104ZFX	S.M.CAP	50V 100nF	
C1592	ECUV1H104ZFX	S.M.CAP	50V 100nF	
C1593	ECA1HM101GB	ELECT	50V 100µF	
C1594	ECUV1H104ZFX	S.M.CAP	50V 100nF	
C1595	ECUV1H104ZFX	S.M.CAP	50V 100nF	
C1596	ECUV1H104ZFX	S.M.CAP	50V 100nF	
C1599	ECA1HM101GB	ELECT	50V 100µF	
C1601	ECUV1H104ZFX	S.M.CAP	50V 100nF	
C1602	ECUV1H104ZFX	S.M.CAP	50V 100nF	

Ref No.	Part No.	Description		
C1603	ECUV1H103KBX	S.M.CAP	50V	10nF
C1604	ECUV1H104ZFX	S.M.CAP	50V	100nF
C1605	ECUV1H104ZFX	S.M.CAP	50V	100nF
C1606	ECUV1H104ZFX	S.M.CAP	50V	100nF
C1607	ECUV1H104ZFX	S.M.CAP	50V	100nF
C1608	ECA1HM101GB	ELECT	50V	100µF
C1610	ECUV1H104ZFX	S.M.CAP	50V	100nF
C1611	ECUV1H103KBX	S.M.CAP	50V	10nF
C1612	ECUV1H104ZFX	S.M.CAP	50V	100nF
C1613	ECUV1H104ZFX	S.M.CAP	50V	100nF
C1614	ECUV1H104ZFX	S.M.CAP	50V	100nF
C1616	ECUV1H152JCX	S.M.CAP	50V	1.5pF
C1617	ECUV1H104ZFX	S.M.CAP	50V	100nF
C1618	ECUV1H104ZFX	S.M.CAP	50V	100nF
C1619	ECUV1H104ZFX	S.M.CAP	50V	100nF
C1620	ECUV1H104ZFX	S.M.CAP	50V	100nF
C1621	ECA1HM101GB	ELECT	50V	100µF
C1622	ECUV1H104ZFX	S.M.CAP	50V	100nF
C1625	ECEA1CN470	ELECT	16V	47µF
C1626	ECUV1H100DCX	S.M.CAP	50V	10pF
C1627	ECUV1H330JCX	S.M.CAP	50V	33pF
C1628	ECUV1H271JCX	S.M.CAP	50V	270pF
C1629	ECUV1H100DCX	S.M.CAP	50V	10pF
C1630	ECUV1H330JCX	S.M.CAP	50V	33pF
C1631	ECUV1H271JCX	S.M.CAP	50V	270pF
C1632	ECUV1H020CCX	S.M.CAP	50V	2pF
C1633	ECUV1H050DCX	S.M.CAP	50V	5pF
C1634	ECUV1H470JCX	S.M.CAP	50V	47pF
C1641	ECA1VM470B	ELECT	35V	47µF
C1642	ECUV1H104ZFX	S.M.CAP	50V	100nF
C1671	ECUV1H330JCX	S.M.CAP	50V	33pF
C1701	ECUV1H104ZFX	S.M.CAP	50V	100nF
C1702	ECUV1H104ZFX	S.M.CAP	50V	100nF
C1703	ECUV1H103ZFX	S.M.CAP	50V	10nF
C1704	ECUV1H104ZFX	S.M.CAP	50V	100nF
C1705	ECA1HM101GB	ELECT	50V	100µF
C1706	ECUV1H104ZFX	S.M.CAP	50V	100nF
C2001	ECA1CM100GB	ELECT	16V	10µF
C2002	ECUV1H104ZFX	S.M.CAP	50V	100nF
C2003	ECUV1H104ZFX	S.M.CAP	50V	100nF
C2004	ECUV1H102JCX	S.M.CAP	50V	1nF
C2005	ECUV1H391JCX	S.M.CAP	50V	390pF
C2006	ECUV1H391JCX	S.M.CAP	50V	390pF
C2007	ECUV1H102JCX	S.M.CAP	50V	1nF
C2008	ECUV1H102JCX	S.M.CAP	50V	1nF
C2009	ECUV1H102JCX	S.M.CAP	50V	1nF
C2010	ECUV1H102JCX	S.M.CAP	50V	1nF
C2011	ECUV1H102JCX	S.M.CAP	50V	1nF
C2012	ECUV1H102JCX	S.M.CAP	50V	1nF
C2014	ECQM1H334J	FILM	50V	330nF
C2017	ECA1CM100GB	ELECT	16V	10µF
C2018	ECA1CM100GB	ELECT	16V	10µF
C2020	ECUV1H104ZFX	S.M.CAP	50V	100nF
C2021	ECUV1H104ZFX	S.M.CAP	50V	100nF
C2022	ECA1HM3R3GB	ELECT	50V	3.3µF
C2023	ECUV1H471JCX	S.M.CAP	50V	470pF
C2024	ECUV1H471JCX	S.M.CAP	50V	470pF
C2025	ECUV1H221JCX	S.M.CAP	50V	220pF
C2026	ECUV1H221JCX	S.M.CAP	50V	220pF
C2027	ECUV1H221JCX	S.M.CAP	50V	220pF
C2028	ECUV1H221JCX	S.M.CAP	50V	220pF
C2029	ECUV1H221JCX	S.M.CAP	50V	220pF
C2030	ECUV1H221JCX	S.M.CAP	50V	220pF
C2031	ECUV1H104ZFX	S.M.CAP	50V	100nF
C2032	ECA1CM100GB	ELECT	16V	10µF
C2034	ECUV1H070DCX	S.M.CAP	50V	7pF
C2035	ECUV1H560JCX	S.M.CAP	50V	56pF
C2036	ECUV1H100DCX	S.M.CAP	50V	10pF
C2037	ECUV1H220JCX	S.M.CAP	50V	22pF
C2039	ECUV1H070DCX	S.M.CAP	50V	7pF
C2040	ECUV1H560JCX	S.M.CAP	50V	56pF
C2041	ECUV1H560JCX	S.M.CAP	50V	56pF

Ref No.	Part No.	Description		
C2042	ECUV1H104ZFX	S.M.CAP	50V	100nF
C2043	ECA1CM100GB	ELECT	16V	10µF
C2044	ECUV1H010CCX	S.M.CAP	50V	1pF
C2045	ECUV1H010CCX	S.M.CAP	50V	1pF
C2050	ECUV1H223ZFX	S.M.CAP	50V	22nF
C2051	ECUV1H223ZFX	S.M.CAP	50V	22nF
C2052	ECUV1H103ZFX	S.M.CAP	50V	10nF
C2053	ECUV1H103ZFX	S.M.CAP	50V	10nF
C2054	ECA1CM331B	ELECT	16V	330µF
C2055	ECA1CM331B	ELECT	16V	330µF
C2058	ECUV1H683ZFX	S.M.CAP	50V	68nF
C2059	ECUV1H102KBX	S.M.CAP	50V	1nF
C2060	ECUV1H102KBX	S.M.CAP	50V	1nF
C2351	ECA1CM471GB	ELECT	16V	470µF
C2352	ECA1CM471GB	ELECT	16V	470µF
C2353	ECA1HM4R7GB	ELECT	50V	4.7µF
C2354	ECKC1H103JB	CERAMIC	50V	10nF
C2355	ECA1HMR33GB	ELECT	50V	0.33µF
C2356	ECKC1H103JB	CERAMIC	50V	10nF
C2360	ECKC1H103JB	CERAMIC	50V	10nF
C2361	ECA1CM471GB	ELECT	16V	470µF
C2362	ECA1CM471GB	ELECT	16V	470µF
C2363	ECA1HM4R7GB	ELECT	50V	4.7µF
C2364	ECKC1H103JB	CERAMIC	50V	10nF
C2365	ECA1HMR33GB	ELECT	50V	0.33µF
C2366	ECKC1H103JB	CERAMIC	50V	10nF
C3001	ECKC1H561J	CERAMIC	50V	560pF
C3002	ECKC1H561J	CERAMIC	50V	560pF
C3005	ECKC1H151J	CERAMIC	50V	150pF
C3101	ECEA1HN4R7UB	ELECT	50V	4.7µF
C3102	ECA1HM470GB	ELECT	50V	47µF
C3103	ECA1CM470GB	ELECT	16V	47µF
C3107	ECA1HM470GB	ELECT	50V	47µF
C3108	ECA1CM470GB	ELECT	16V	47µF
C3111	ECUV1H102JCX	S.M.CAP	50V	1nF
C3113	ECA1HM470GB	ELECT	50V	47µF
C3114	ECA1CM470GB	ELECT	16V	47µF
C3115	ECEA1HNR47UB	ELECT	50V	0.47µF
C3117	ECEA1HN4R7UB	ELECT	50V	4.7µF
C3119	ECA1HM470GB	ELECT	50V	47µF
C3120	ECA1CM470GB	ELECT	16V	47µF
C3123	ECEA1HN4R7UB	ELECT	50V	4.7µF
C3126	ECEA1HN4R7UB	ELECT	50V	4.7µF
C3128	ECEA1HN4R7UB	ELECT	50V	4.7µF
C3130	ECEA1HN4R7UB	ELECT	50V	4.7µF
C3131	ECUV1H473KBX	S.M.CAP	50V	47nF
C3132	ECA1CM470GB	ELECT	16V	47µF
C3133	ECA1CM470GB	ELECT	16V	47µF
C3134	ECA1CM470GB	ELECT	16V	47µF
C3136	ECA1CM470GB	ELECT	16V	47µF
C3137	ECA1HM470GB	ELECT	50V	47µF
C3138	ECA1HM470GB	ELECT	50V	47µF
C3139	ECUV1H222JCX	S.M.CAP	50V	2.2nF
C3140	ECUV1H222JCX	S.M.CAP	50V	2.2nF
C3143	ECUV1H561JCX	S.M.CAP	50V	560pF
C3146	ECUV1H561JCX	S.M.CAP	50V	560pF
C3148	ECA1HM4R7GB	ELECT	50V	4.7µF
C3149	ECUV1H561JCX	S.M.CAP	50V	560pF
C3150	ECA1HM4R7GB	ELECT	50V	4.7µF
C3151	ECUV1H561JCX	S.M.CAP	50V	560pF
C3154	ECUV1H104ZFX	S.M.CAP	50V	100nF
C3156	ECA1CM470GB	ELECT	16V	47µF
C3158	ECUV1H102JCX	S.M.CAP	50V	1nF
C3160	ECUV1H104ZFX	S.M.CAP	50V	100nF
C3162	ECA1CM471GB	ELECT	16V	470µF
C3163	ECA1HMR47GB	ELECT	50V	0.47µF
C3165	ECA1HM470GB	ELECT	50V	47µF
C3169	ECUV1H102JCX	S.M.CAP	50V	1nF
C3170	ECUV1H561JCX	S.M.CAP	50V	560pF
C3172	ECUV1H561JCX	S.M.CAP	50V	560pF
C3173	ECA1HMR47GB	ELECT	50V	0.47µF
C3174	ECUV1H561JCX	S.M.CAP	50V	560pF

Ref No.	Part No.	Description
C3178	ECUV1H561JCX	S.M.CAP 50V 560pF
C3180	ECA1HMR47GB	ELECT 50V 0.47µF
C3181	ERJ6GEY0R00	S.M.CARB 0.1W 5% 0Ω
C3182	ECUV1H102JCX	S.M.CAP 50V 1nF
C3183	ERJ6GEY0R00	S.M.CARB 0.1W 5% 0Ω
C3184	ECUV1H473KBX	S.M.CAP 50V 47nF
C3185	ERJ6GEY0R00	S.M.CARB 0.1W 5% 0Ω
C3186	ECEA1HNR47UB	ELECT 50V 0.47µF
C3187	ECA1HM470GB	ELECT 50V 47µF
C3188	ECEA1CN470	ELECT 16V 47µF
C3190	ECA1HMR47GB	ELECT 50V 0.47µF
C3191	ECA1HM470GB	ELECT 50V 47µF
C3192	ECUV1H473KBX	S.M.CAP 50V 47nF
C3201	ECA1HM010GB	ELECT 50V 1µF
C3202	ECUV1H473ZFX	S.M.CAP 50V 47nF
C3203	ECA1CM100GB	ELECT 16V 10µF
C3204	ECUV1H473ZFX	S.M.CAP 50V 47nF
C3501	ECUV1H220JCX	S.M.CAP 50V 22pF
C3502	ECUV1H220JCX	S.M.CAP 50V 22pF
C3503	ECEA1HKN010	ELECT 50V 1µF
C3504	ECUV1H224ZFX	S.M.CAP 50V 0.22µF
C3510	ECUV1H103ZFX	S.M.CAP 50V 10nF
C3511	ECA1HM101GB	ELECT 50V 100µF
C3512	ECUV1H104ZFX	S.M.CAP 50V 100nF
C3514	ECUV1H104ZFX	S.M.CAP 50V 100nF
C3515	ECA0JM331GB	ELECT 6.3V 330µF
C3516	ECUV1H104ZFX	S.M.CAP 50V 100nF
C3521	ECA1HM101GB	ELECT 50V 100µF
C3522	ECUV1H104ZFX	S.M.CAP 50V 100nF
C3801	ECA1HM010GB	ELECT 50V 1µF
C3802	ECUV1H104ZFX	S.M.CAP 50V 100nF
C3803	ECA1CM471GB	ELECT 16V 470µF
C3807	ECUV1H104ZFX	S.M.CAP 50V 100nF
C3808	ECUV1H104ZFX	S.M.CAP 50V 100nF
C3809	ECA0JM101G	ELECT 6.3V 100µF
C3810	ECUV1H103KBX	S.M.CAP 50V 10nF
C3812	ECA1CM221GB	ELECT 16V 220µF

DIODES

D001	MA4020	DIODE
D002	MA4020	DIODE
D103	BA582	DIODE
D104	BA582	DIODE
D251	MA165TA5	DIODE 1SS133T-77
D252	MA165TA5	DIODE 1SS133T-77
D253	MA165TA5	DIODE 1SS133T-77
D254	MA165TA5	DIODE 1SS133T-77
D401	MA165TA5	DIODE 1SS133T-77
D451	MA4056	DIODE
D452	MA2330-ALF	DIODE
D453	TVSEM01ZV0	DIODE
D502	1SS254T-77	DIODE
D503	EU02	DIODE
D504	EU02	DIODE
D531	1SS254T-77	DIODE
D532	1SS254T-77	DIODE
D533	1SS254T-77	DIODE
D551	EU02	DIODE
D556	AU02V0	DIODE
D557	ERC91-02L9	DIODE
D558	AU02V0	DIODE
D559	MTZJT-7736A	DIODE
D560	1SS252T-77	DIODE
D561	1SS254T-77	DIODE
D563	RH3GLF102	DIODE
D571	FMV-3GULF027	DIODE
D574	1SS252T-77	DIODE
D575	1SS252T-77	DIODE

Ref No.	Part No.	Description
D602	MA165TA5	DIODE 1SS133T-77
D603	MA165TA5	DIODE 1SS133T-77
D604	MA4062	DIODE
D706	MA165TA5	DIODE 1SS133T-77
D707	MA188TA	DIODE
D806	TF361MALF3	DIODE
D807	D6SB80LF-B	DIODE
D808	1SS254T-77	DIODE
D809	ERA22-02V3	DIODE
D810	MA2160LFS	DIODE
D812	MTZJT-775.6B	DIODE
D813	MA700TA5	DIODE
D814	AU01ZV0	DIODE
D815	PC123FY2	DIODE
D817	D5L60F4015	DIODE
D818	TMPG10G3	DIODE
D819	ERA81004V3	DIODE
D820	MA4100	DIODE
D821	EU02AV0	DIODE
D822	MTZJT-7718C	DIODE
D845	1SS254T-77	DIODE
D846	TVSS1WBS20	DIODE
D847	ERA15-01V1	DIODE
D848	EU02	DIODE
D849	FMGG26S	DIODE
D850	EU02	DIODE
D851	FMGG2CS	DIODE
D852	MTZJT-779.1C	DIODE
D853	1SS254T-77	DIODE
D854	1SS254T-77	DIODE
D855	D10SC6MRL	DIODE
D857	FML22SLF610	DIODE
D860	1SS254T-77	DIODE
D861	MTZJT-7713B	DIODE
D862	MA4104	DIODE
D1051	SLR56UR3FLF	LED
D1052	AU01V0	DIODE
D1053	AU01V0	DIODE
D1054	AU01V0	DIODE
D1055	AU01V0	DIODE
D1056	AU01V0	DIODE
D1057	AU01V0	DIODE
D1102	MA4051	DIODE
D1107	MTZJT-775.6A	DIODE
D1108	1SS254T-77	DIODE
D1109	1SS254T-77	DIODE
D1113	MA4051	DIODE
D1552	MA151ATX	DIODE
D2005	MA723TA5	DIODE
D2006	MA723TA5	DIODE
D3101	PMLL5242B	DIODE
D3102	PMLL5242B	DIODE
D3103	PMLL5242B	DIODE
D3105	PMLL5242B	DIODE
D3107	PMLL5242B	DIODE
D3109	PMLL5242B	DIODE
D3110	PMLL5242B	DIODE
D3111	PMLL5242B	DIODE
D3112	PMLL5242B	DIODE
D3115	PMLL5242B	DIODE
D3117	PMLL5242B	DIODE
D3120	RLS72TE-11	DIODE OR PMLL4148
D3501	MA4030	DIODE
D3801	MA4043	DIODE
D3802	MTZJT-778.2A	DIODE
D3803	ERA81004V3	DIODE
D3805	MA4091	DIODE
D3806	MA165TA5	DIODE 1SS133T-77
D3807	MA165TA5	DIODE 1SS133T-77

Ref No.	Part No.	Description			
FUSES					
F532	TR5-T1250	FUSE		△	
F801	XBA2C50TH15	FUSE			
F845	TR5-T2000	FUSE		△	
F846	TR5-T1250	FUSE		△	
F8011	EYF52BC	FUSE HOLDER			
F8012	EYF52BC	FUSE HOLDER			
TERMINALS AND LINKS					
JA2	ERJ6GEY0R00	S.M.CARB	0.1W	5%	0Ω
JA3	ERJ6GEY0R00	S.M.CARB	0.1W	5%	0Ω
JA5	ERJ6GEY0R00	S.M.CARB	0.1W	5%	0Ω
JA6	ERJ6GEY0R00	S.M.CARB	0.1W	5%	0Ω
JA7	ERJ6GEY0R00	S.M.CARB	0.1W	5%	0Ω
JA8	ERJ6GEY0R00	S.M.CARB	0.1W	5%	0Ω
JA9	ERJ6GEY0R00	S.M.CARB	0.1W	5%	0Ω
JK3001	TJBA039	A/V TERMINAL			
JSB3	ERJ6GEY0R00	S.M.CARB	0.1W	5%	0Ω
JSE010	ERJ6GEY0R00	S.M.CARB	0.1W	5%	0Ω
JSE011	ERJ6GEY0R00	S.M.CARB	0.1W	5%	0Ω
JSE012	ERJ6GEY0R00	S.M.CARB	0.1W	5%	0Ω
JSE015	ERJ6GEY0R00	S.M.CARB	0.1W	5%	0Ω
JSE022	ERJ6GEY0R00	S.M.CARB	0.1W	5%	0Ω
JSE023	ERJ6GEY0R00	S.M.CARB	0.1W	5%	0Ω
JSE024	ERJ6GEY0R00	S.M.CARB	0.1W	5%	0Ω
JSE025	ERJ6GEY0R00	S.M.CARB	0.1W	5%	0Ω
JSE03	ERJ6GEY0R00	S.M.CARB	0.1W	5%	0Ω
JSE042	ERJ6GEY0R00	S.M.CARB	0.1W	5%	0Ω
JSE050	ERJ6GEY0R00	S.M.CARB	0.1W	5%	0Ω
JSE056	ERJ6GEY0R00	S.M.CARB	0.1W	5%	0Ω
JSE057	ERJ6GEY0R00	S.M.CARB	0.1W	5%	0Ω
JSE058	ERJ6GEY0R00	S.M.CARB	0.1W	5%	0Ω
JSE062	ERJ6GEY0R00	S.M.CARB	0.1W	5%	0Ω
JSE064	ERJ6GEY0R00	S.M.CARB	0.1W	5%	0Ω
JSE066	ERJ6GEY0R00	S.M.CARB	0.1W	5%	0Ω
JSE07	ERJ6GEY0R00	S.M.CARB	0.1W	5%	0Ω
JSE09	ERJ6GEY0R00	S.M.CARB	0.1W	5%	0Ω
JSF001	ERJ6GEY0R00	S.M.CARB	0.1W	5%	0Ω
JSF002	ERJ6GEY0R00	S.M.CARB	0.1W	5%	0Ω
JSF003	ERJ6GEY0R00	S.M.CARB	0.1W	5%	0Ω
JSF004	ERJ6GEY0R00	S.M.CARB	0.1W	5%	0Ω
JSF005	ERJ6GEY0R00	S.M.CARB	0.1W	5%	0Ω
JSF006	ERJ6GEY0R00	S.M.CARB	0.1W	5%	0Ω
JSF008	ERJ6GEY0R00	S.M.CARB	0.1W	5%	0Ω
JSF011	ERJ6GEY0R00	S.M.CARB	0.1W	5%	0Ω
JSF012	ERJ6GEY0R00	S.M.CARB	0.1W	5%	0Ω
JSF014	ERJ6GEY0R00	S.M.CARB	0.1W	5%	0Ω
JSF015	ERJ6GEY0R00	S.M.CARB	0.1W	5%	0Ω
JSF026	ERJ6GEY0R00	S.M.CARB	0.1W	5%	0Ω
JSF036	ERJ6GEY0R00	S.M.CARB	0.1W	5%	0Ω
JSF039	ERJ6GEY0R00	S.M.CARB	0.1W	5%	0Ω
JSF040	ERJ6GEY0R00	S.M.CARB	0.1W	5%	0Ω
JSF041	ERJ6GEY0R00	S.M.CARB	0.1W	5%	0Ω
JSF042	ERJ6GEY0R00	S.M.CARB	0.1W	5%	0Ω
JSF044	ERJ6GEY0R00	S.M.CARB	0.1W	5%	0Ω
JSF045	ERJ6GEY0R00	S.M.CARB	0.1W	5%	0Ω
JSF046	ERJ6GEY0R00	S.M.CARB	0.1W	5%	0Ω
JSF048	ERJ6GEY0R00	S.M.CARB	0.1W	5%	0Ω
JSF049	ERJ6GEY0R00	S.M.CARB	0.1W	5%	0Ω
JSF050	ERJ6GEY0R00	S.M.CARB	0.1W	5%	0Ω
JSF051	ERJ6GEY0R00	S.M.CARB	0.1W	5%	0Ω
JSF055	ERJ6GEY0R00	S.M.CARB	0.1W	5%	0Ω
JSF056	ERJ6GEY0R00	S.M.CARB	0.1W	5%	0Ω
JSF057	ERJ6GEY0R00	S.M.CARB	0.1W	5%	0Ω
JSF064	ERJ6GEY0R00	S.M.CARB	0.1W	5%	0Ω
JSF066	ERJ6GEY0R00	S.M.CARB	0.1W	5%	0Ω
JSF072	ERJ6GEY0R00	S.M.CARB	0.1W	5%	0Ω
JSF073	ERJ6GEY0R00	S.M.CARB	0.1W	5%	0Ω
JSF075	ERJ6GEY0R00	S.M.CARB	0.1W	5%	0Ω

Ref No.	Part No.	Description			
JSF076	ERJ6GEY0R00	S.M.CARB	0.1W	5%	0Ω
JSF077	ERJ6GEY0R00	S.M.CARB	0.1W	5%	0Ω
JSF080	ERJ6GEY0R00	S.M.CARB	0.1W	5%	0Ω
JSF081	ERJ6GEY0R00	S.M.CARB	0.1W	5%	0Ω
JSF086	ERJ6GEY0R00	S.M.CARB	0.1W	5%	0Ω
JSF087	ERJ6GEY0R00	S.M.CARB	0.1W	5%	0Ω
JSF088	ERJ6GEY0R00	S.M.CARB	0.1W	5%	0Ω
JSF089	ERJ6GEY0R00	S.M.CARB	0.1W	5%	0Ω
JSF090	ERJ6GEY0R00	S.M.CARB	0.1W	5%	0Ω
JSF091	ERJ6GEY0R00	S.M.CARB	0.1W	5%	0Ω
JSH004	ERJ6GEY0R00	S.M.CARB	0.1W	5%	0Ω
JSH005	ERJ6GEY0R00	S.M.CARB	0.1W	5%	0Ω
JSH01	ERJ6GEY0R00	S.M.CARB	0.1W	5%	0Ω
JSH010	ERJ6GEY0R00	S.M.CARB	0.1W	5%	0Ω
JSH02	ERJ6GEY0R00	S.M.CARB	0.1W	5%	0Ω
COILS					
LC1507	EXCEMT103DTM	COIL			
LC1508	EXCEMT103DTM	COIL			
LC1509	EXCEMT103DTM	COIL			
LC1510	EXCEMT103DTM	COIL			
LC1610	ELKTR560BA	DELAY LINE			
L002	TLT047K991R	COIL			
L004	TLT047K991R	COIL			
L005	TLT047K991R	COIL			
L102	TLT056K991R	COIL			
L103	EQV7EN203B	COIL			
L105	ELESNR22MA	COIL			
L107	ELESNR22MA	COIL			
L108	ELESNR22MA	COIL			
L109	EIL7EN015Q	COIL			
L110	EQL7EN022Q	COIL			
L113	EIL7EN015Q	COIL			
L252	EXCELSA35T	COIL			
L253	EXCELSA35T	COIL			
L254	EXCELSA35T	COIL			
L255	EXCELSA35T	COIL			
L401	EXCELDR35V	COIL			
L402	EXCELDR35V	COIL			
L451	EXCELDR35V	COIL			
L552	EXCELSA35T	COIL			
L553	EXCELSA35T	COIL			
L554	EXCELDR35V	COIL			
L555	ERD25TC0T	CARBON	0.25W	5%	0Ω
L556	EXCELSA24T	COIL			
L557	EXCELSA24T	COIL			
L571	ELC18B221L	COIL			
L572	ELHKLBO25B	COIL			
L573	ELHKLBO26B	COIL			
L575	ELC18B271E	COIL			
L601	TLT047K991R	COIL			
L602	TLT047K991R	COIL			
L603	TLT047K991R	COIL			
L605	EXCELDR25V	COIL			
L801	ELF18D424F	COIL			
L802	ELF18D424F	COIL			
L807	ELF18D860D	LINE FILTER			
L808	EXCELSA35T	COIL			
L809	EXCELDR35C	COIL			
L810	EXCELSA39V	COIL			
L811	EXCELSA39V	COIL			
L812	EXCELDR35V	COIL			
L813	EXCELDR35V	COIL			
L817	EXCELDR35V	COIL			
L845	EXCELSA35T	COIL			
L847	EXCELSA35B	COIL			
L848	EXCELSA35T	COIL			
L850	EXCELSA35T	COIL			
L851	EXCELSA35B	COIL			
L852	EXCELSA35T	COIL			
L853	EXCELSA35T	COIL			

Ref No.	Part No.	Description
L854	ELEIE150KA	COIL
L856	EXCELSA35T	COIL
L861	EXCELSA35T	COIL
L862	EXCELSA35T	COIL
L864	EXCELD35V	COIL
L1102	EXCELD35V	COIL
L1103	EXCELD35V	COIL
L1104	EXCELSA35T	COIL
L1105	ELEXT4R7KA	COIL
L1302	TLT100K991R	COIL
L1304	TLT100K991R	COIL
L1307	ERD25TC0T	CARBON 0.25W 5% 0Ω
L1501	EXCELD35V	COIL
L1504	TLT018K991R	COIL
L1505	ELESN120JA	COIL
L1506	ELESN120JA	COIL
L1507	ELESN3R3JA	COIL
L1552	EXCELD35V	COIL
L1553	EXCELD35V	COIL
L1575	EXCELD35V	COIL
L1576	EXCELD35V	COIL
L1601	EXCELD35V	COIL
L1602	EXCELD35V	COIL
L1603	TLT100K991R	COIL
L1604	TLT100K991R	COIL
L1605	TLT100K991R	COIL
L1606	TLT100K991R	COIL
L1607	EXCELD35V	COIL
L1621	ELESN3R3JA	COIL
L1622	ELESN3R3JA	COIL
L1623	TLT022K991R	COIL
L1641	EXCELD35V	COIL
L1701	EXCELD35V	COIL
L2001	TLT047K991R	COIL
L2003	EXCELD35V	COIL
L2004	TLT068K991R	COIL
L2005	TLT068K991R	COIL
L2351	ELEBR6R8KA	COIL
L2361	ELEBR6R8KA	COIL
L3001	ELEBR6R8KA	COIL
L3002	ELEBR6R8KA	COIL
L3003	ELEBR470KA	COIL
L3107	EXCELD35V	COIL
L3108	EXCELD35V	COIL
L3109	EXCELD35V	COIL
L3110	EXCELD35V	COIL
L3111	EXCELD35V	COIL
L3112	EXCELD35V	COIL
L3113	EXCELD35V	COIL
L3114	EXCELD35V	COIL
L3503	EXCELD35V	COIL
L3507	EXCELD35V	COIL
L3509	EXCELD35V	COIL
L3511	TLT100K991R	COIL

TRANSISTORS

Q008	BC847B	TRANSISTOR OR 2SD601ATX
Q101	BC847B	TRANSISTOR OR 2SD601ATX
Q102	BC847B	TRANSISTOR OR 2SD601ATX
Q103	BC847B	TRANSISTOR OR 2SD601ATX
Q104	BC847B	TRANSISTOR OR 2SD601ATX
Q105	BC847B	TRANSISTOR OR 2SD601ATX
Q106	BF799E6327	CHIP TRANSISTOR
Q107	BC847B	TRANSISTOR OR 2SD601ATX
Q108	BC847B	TRANSISTOR OR 2SD601ATX
Q109	BC860B	TRANSISTOR
Q251	BC847B	TRANSISTOR OR 2SD601ATX
Q252	BC847B	TRANSISTOR OR 2SD601ATX
Q401	BC847B	TRANSISTOR OR 2SD601ATX
Q502	2SC2925STA	TRANSISTOR

Ref No.	Part No.	Description
Q531	BC547B	TRANSISTOR
Q532	BC547B	TRANSISTOR
Q533	BC547B	TRANSISTOR
Q535	BC547B	TRANSISTOR
Q551	BC547B	TRANSISTOR
Q552	2SC5418001TV	TRANSISTOR
Q553	2SC1473-RN	TRANSISTOR
Q554	2SC1473-RN	TRANSISTOR
Q573	BC557B	TRANSISTOR
Q574	2SD1265AOPLB	TRANSISTOR
Q601	BC847B	TRANSISTOR OR 2SD601ATX
Q602	BC857B	TRANSISTOR OR 2SB709ATX
Q603	BC847B	TRANSISTOR OR 2SD601ATX
Q604	BC857B	TRANSISTOR OR 2SB709ATX
Q605	BC857B	TRANSISTOR OR 2SB709ATX
Q606	BC847B	TRANSISTOR OR 2SD601ATX
Q607	BC847B	TRANSISTOR OR 2SD601ATX
Q608	BC847B	TRANSISTOR OR 2SD601ATX
Q609	BC847B	TRANSISTOR OR 2SD601ATX
Q610	BC847B	TRANSISTOR OR 2SD601ATX
Q611	BC847B	TRANSISTOR OR 2SD601ATX
Q612	BC847B	TRANSISTOR OR 2SD601ATX
Q801	2SK1365LBMAT	TRANSISTOR
Q803	2SD965-R	TRANSISTOR
Q804	2SA719-TA	TRANSISTOR
Q845	2SA684R	TRANSISTOR
Q846	BC547B	TRANSISTOR
Q847	BC557B	TRANSISTOR
Q848	BC547B	TRANSISTOR
Q849	2SA1018QTA	TRANSISTOR
Q850	2SD1474PLB	TRANSISTOR
Q851	BC547B	TRANSISTOR
Q852	BC547B	TRANSISTOR
Q1052	BC557B	TRANSISTOR
Q1101	BC847B	TRANSISTOR OR 2SD601ATX
Q1102	BC847B	TRANSISTOR OR 2SD601ATX
Q1103	BC847B	TRANSISTOR OR 2SD601ATX
Q1108	BC847B	TRANSISTOR OR 2SD601ATX
Q1112	2SC3757QRTX	TRANSISTOR
Q1191	BC847B	TRANSISTOR OR 2SD601ATX
Q1301	BC847B	TRANSISTOR OR 2SD601ATX
Q1303	BC847B	TRANSISTOR OR 2SD601ATX
Q1501	BC847B	TRANSISTOR OR 2SD601ATX
Q1502	BC847B	TRANSISTOR OR 2SD601ATX
Q1503	BC847B	TRANSISTOR OR 2SD601ATX
Q1505	BC847B	TRANSISTOR OR 2SD601ATX
Q1561	BC847B	TRANSISTOR OR 2SD601ATX
Q1575	BC847B	TRANSISTOR OR 2SD601ATX
Q1635	BC857B	TRANSISTOR OR 2SB709ATX
Q1636	BC857B	TRANSISTOR OR 2SB709ATX
Q1642	BC847B	TRANSISTOR OR 2SD601ATX
Q1643	BC847B	TRANSISTOR OR 2SD601ATX
Q1644	BC857B	TRANSISTOR OR 2SB709ATX
Q1647	BC847B	TRANSISTOR OR 2SD601ATX
Q1648	BC857B	TRANSISTOR OR 2SB709ATX
Q1649	BC857B	TRANSISTOR OR 2SB709ATX
Q1650	BC857B	TRANSISTOR OR 2SB709ATX
Q2001	BC860B	TRANSISTOR
Q2002	BC860B	TRANSISTOR
Q2003	BC860B	TRANSISTOR
Q2004	BC860B	TRANSISTOR
Q2006	BC857B	TRANSISTOR OR 2SB709ATX
Q2007	BC847B	TRANSISTOR OR 2SD601ATX
Q2351	BC547B	TRANSISTOR
Q2352	BC547B	TRANSISTOR
Q2353	BC557B	TRANSISTOR
Q2361	BC547B	TRANSISTOR
Q2362	BC547B	TRANSISTOR
Q2363	BC557B	TRANSISTOR
Q3101	BC847B	TRANSISTOR OR 2SD601ATX
Q3102	BC847B	TRANSISTOR OR 2SD601ATX
Q3105	BC847B	TRANSISTOR OR 2SD601ATX

Ref No.	Part No.	Description
Q3106	BC847B	TRANSISTOR OR 2SD601ATX
Q3107	BC857B	TRANSISTOR OR 2SB709ATX
Q3108	BC847B	TRANSISTOR OR 2SD601ATX
Q3113	BC847B	TRANSISTOR OR 2SD601ATX
Q3115	BC857B	TRANSISTOR OR 2SB709ATX
Q3201	BC847B	TRANSISTOR OR 2SD601ATX
Q3501	BC847B	TRANSISTOR OR 2SD601ATX
Q3502	BC847B	TRANSISTOR OR 2SD601ATX
Q3503	2SC3130TX	TRANSISTOR
Q3801	2SD1474PLB	TRANSISTOR

RESISTOR

RL806	TSE1885-1	RELAY
R003	ERJ6GEYJ223	S.M.CARB 0.1W 5% 22KΩ
R006	ERJ6GEYJ393	S.M.CARB 0.1W 5% 39KΩ
R011	ERJ6GEYJ101	S.M.CARB 0.1W 5% 100Ω
R012	ERJ6GEYJ101	S.M.CARB 0.1W 5% 100Ω
R101	ERJ6GEYJ102	S.M.CARB 0.1W 5% 1KΩ
R102	ERJ6GEYJ101	S.M.CARB 0.1W 5% 100Ω
R103	ERJ6GEYJ103	S.M.CARB 0.1W 5% 10KΩ
R104	ERJ6GEY0R00	S.M.CARB 0.1W 5% 0Ω
R105	ERJ6GEYJ331	S.M.CARB 0.1W 5% 330Ω
R106	ERJ6GEYJ680	S.M.CARB 0.1W 5% 68Ω
R107	ERJ6GEYJ123	S.M.CARB 0.1W 5% 12KΩ
R109	ERJ6GEYJ102	S.M.CARB 0.1W 5% 1KΩ
R110	ERJ6GEYJ103	S.M.CARB 0.1W 5% 10KΩ
R111	ERJ6GEYJ331	S.M.CARB 0.1W 5% 330Ω
R113	ERJ6GEY0R00	S.M.CARB 0.1W 5% 0Ω
R115	ERJ6GEYJ121	S.M.CARB 0.1W 5% 120Ω
R117	ERJ6GEYJ683	S.M.CARB 0.1W 5% 68KΩ
R118	ERJ6GEYJ151	S.M.CARB 0.1W 5% 150Ω
R119	ERJ6GEY0R00	S.M.CARB 0.1W 5% 0Ω
R120	ERJ6GEYJ223	S.M.CARB 0.1W 5% 22KΩ
R121	ERJ6GEYJ331	S.M.CARB 0.1W 5% 330Ω
R122	EVNDXAA03B24	CONTROL 20KΩ
R123	ERJ6GEYJ104	S.M.CARB 0.1W 5% 100KΩ
R124	ERJ6GEYJ223	S.M.CARB 0.1W 5% 22KΩ
R125	ERJ6GEYJ101	S.M.CARB 0.1W 5% 100Ω
R126	ERJ6GEYJ223	S.M.CARB 0.1W 5% 22KΩ
R127	ERJ6GEYJ473	S.M.CARB 0.1W 5% 47KΩ
R128	ERJ6GEYJ181	S.M.CARB 0.1W 5% 180Ω
R130	ERJ6GEY0R00	S.M.CARB 0.1W 5% 0Ω
R132	ERJ6GEYJ122	S.M.CARB 0.1W 5% 1K2Ω
R133	ERJ6GEYJ122	S.M.CARB 0.1W 5% 1K2Ω
R134	ERJ6GEYJ103	S.M.CARB 0.1W 5% 10KΩ
R135	ERJ6GEYJ103	S.M.CARB 0.1W 5% 10KΩ
R136	ERJ6GEYJ122	S.M.CARB 0.1W 5% 1K2Ω
R137	ERJ6GEYJ104	S.M.CARB 0.1W 5% 100KΩ
R138	ERJ6GEYJ122	S.M.CARB 0.1W 5% 1K2Ω
R139	ERJ6GEYJ154	S.M.CARB 0.1W 5% 150KΩ
R141	ERJ6GEYJ330	S.M.CARB 0.1W 5% 33Ω
R142	ERJ6GEYJ271	S.M.CARB 0.1W 5% 270Ω
R143	ERJ6GEYJ123	S.M.CARB 0.1W 5% 12KΩ
R144	ERJ6GEYJ152	S.M.CARB 0.1W 5% 1K5Ω
R145	ERJ6GEYJ331	S.M.CARB 0.1W 5% 330Ω
R146	ERJ6GEYJ104	S.M.CARB 0.1W 5% 100KΩ
R147	ERJ6GEYJ122	S.M.CARB 0.1W 5% 1K2Ω
R148	ERJ6GEYJ183	S.M.CARB 0.1W 5% 18KΩ
R149	ERJ6GEYJ682	S.M.CARB 0.1W 5% 6K8Ω
R150	ERJ6GEYJ221	S.M.CARB 0.1W 5% 220Ω
R151	ERJ6GEYJ471	S.M.CARB 0.1W 5% 470Ω
R152	ERJ6GEYJ103	S.M.CARB 0.1W 5% 10KΩ
R154	ERJ6GEY0R00	S.M.CARB 0.1W 5% 0Ω
R156	ERJ6GEY0R00	S.M.CARB 0.1W 5% 0Ω
R157	ERJ6GEYJ101	S.M.CARB 0.1W 5% 100Ω
R159	ERJ6GEYJ153	S.M.CARB 0.1W 5% 15KΩ
R251	ERJ6GEYJ2R2	SM.CARB0.125W 5% 2R2Ω
R252	ERJ6GEYJ153	S.M.CARB 0.1W 5% 15KΩ
R253	ERJ6GEY0R00	S.M.CARB 0.1W 5% 0Ω
R254	ERJ6GEYJ223	S.M.CARB 0.1W 5% 22KΩ

Ref No.	Part No.	Description
R255	ERJ6GEYJ331	S.M.CARB 0.1W 5% 330Ω
R256	ERJ6GEYJ104	S.M.CARB 0.1W 5% 100KΩ
R257	ERJ6GEYJ102	S.M.CARB 0.1W 5% 1KΩ
R258	ERJ6GEYJ471	S.M.CARB 0.1W 5% 470Ω
R259	ERG3SJS120	METAL 3W 5% 12Ω ▲
R260	ERJ6GEYJ2R2	SM.CARB0.125W 5% 2R2Ω
R261	ERJ6GEYJ153	S.M.CARB 0.1W 5% 15KΩ
R262	ERJ6GEYJ223	S.M.CARB 0.1W 5% 22KΩ
R263	ERJ6GEYJ331	S.M.CARB 0.1W 5% 330Ω
R264	ERJ6GEYJ104	S.M.CARB 0.1W 5% 100KΩ
R265	ERJ6GEYJ471	S.M.CARB 0.1W 5% 470Ω
R266	ERJ6GEYJ102	S.M.CARB 0.1W 5% 1KΩ
R267	ERJ6GEYJ151	S.M.CARB 0.1W 5% 150Ω
R268	ERJ6GEYJ151	S.M.CARB 0.1W 5% 150Ω
R269	ERJ6GEY0R00	S.M.CARB 0.1W 5% 0Ω
R270	ERG3SJS120	METAL 3W 5% 12Ω ▲
R401	ERJ6GEYJ153	S.M.CARB 0.1W 5% 15KΩ
R402	ERJ6GEYJ332	S.M.CARB 0.1W 5% 3K3Ω
R403	ERJ6GEYJ392	S.M.CARB 0.1W 5% 3K9Ω
R406	ERJ6GEYJ393	S.M.CARB 0.1W 5% 39KΩ
R407	ERJ6GEYJ101	S.M.CARB 0.1W 5% 100Ω
R408	ERJ6GEYJ101	S.M.CARB 0.1W 5% 100Ω
R409	ERJ6GEYJ102	S.M.CARB 0.1W 5% 1KΩ
R410	ERJ6GEYJ100	S.M.CARB 0.1W 5% 10Ω
R411	ERJ6GEYJ123	S.M.CARB 0.1W 5% 12KΩ
R412	ERJ6GEYJ103	S.M.CARB 0.1W 5% 10KΩ
R451	ERJ6GEYJ302	S.M.CARB 0.1W 5% 3K0Ω
R452	ERJ6GEYJ563	S.M.CARB 0.1W 5% 56KΩ
R453	ERG3FJX820D	METAL 3W 5% 82Ω ▲
R454	ERX12SJ1R0	METAL 12W 5% 1R0Ω
R455	ERX12SJR82P	METAL 12W 5% R82Ω
R456	ERQ14AJ220	FUSIBLE 14W 5% 22Ω ▲
R457	ERDS1TJ223	CARBON 0.5W 5% 22KΩ
R458	ERG1SJ272	METAL 1W 5% 2K7Ω ▲
R459	ERJ6GEYJ393	S.M.CARB 0.1W 5% 39KΩ
R504	ERD25TJ271	CARBON 0.25W 5% 270Ω
R505	ERG3SJS330	METAL 3W 5% 33Ω ▲
R506	ERDS1TJ152	CARBON 0.5W 5% 1K5Ω
R507	ERDS1TJ152	CARBON 0.5W 5% 1K5Ω
R531	ERD25TJ103	CARBON 0.25W 5% 10KΩ
R532	ERD25TJ103	CARBON 0.25W 5% 10KΩ
R533	ERD25TJ683	CARBON 0.25W 5% 68KΩ
R534	ERD25TJ473	CARBON 0.25W 5% 47KΩ
R535	ERD25TJ472	CARBON 0.25W 5% 4K7Ω
R536	ERD25TJ103	CARBON 0.25W 5% 10KΩ
R539	ERD25TJ103	CARBON 0.25W 5% 10KΩ
R540	ERD25TJ183	CARBON 0.25W 5% 18KΩ
R541	ERD25TJ102	CARBON 0.25W 5% 1KΩ
R542	ERD25TJ103	CARBON 0.25W 5% 10KΩ
R543	ERD25TJ222	CARBON 0.25W 5% 2K2Ω
R547	ERD25TJ103	CARBON 0.25W 5% 10KΩ
R551	ERD25TJ103	CARBON 0.25W 5% 10KΩ
R552	ERD25TJ473	CARBON 0.25W 5% 47KΩ
R553	ERD25TJ103	CARBON 0.25W 5% 10KΩ
R554	ERX3SJSR27H	METAL 3W 5% R27Ω
R555	ERO25CKF2802	METAL 25W 1% 28KΩ ▲
R556	ERO50PKF2802	METAL 50W 1% 28KΩ ▲
R557	ERO25CKF1073	METAL 25W 1% 107KΩ ▲
R559	ERO25CKF1002	METAL 0.25W 1% 10KΩ ▲
R560	ERD25TJ222	CARBON 0.25W 5% 2K2Ω
R562	ERD25TJ473	CARBON 0.25W 5% 47KΩ
R564	ERDS1TJ394	CARBON 0.5W 5% 390KΩ
R565	ERQ14AJW2R2	FUSIBLE 14W 5% 2R2Ω ▲
R566	ERDS1TJ183	CARBON 0.5W 5% 18KΩ
R567	ERG2ANJ223	METAL 2W 5% 22KΩ
R568	ERQ12HJ330	METAL 0.5W 5% 33Ω ▲
R569	ERDS1TJ120	CARBON 0.5W 5% 12Ω
R570	ERD25TJ103	CARBON 0.25W 5% 10KΩ
R571	ERX3FJ2R7H	METAL 3W 5% 2R7Ω
R572	ERG3FJ821	METAL 3W 5% 820Ω ▲
R574	ERG3FJ151	METAL 3W 5% 150Ω ▲

Ref No.	Part No.	Description
R579	ERD25TJ274	CARBON 0.25W 5% 270KΩ
R580	ERD25TJ563	CARBON 0.25W 5% 56KΩ
R581	ERD25TJ104	CARBON 0.25W 5% 100KΩ
R582	ERD25TJ225	CARBON 0.25W 5% 2M2Ω
R583	ERD25TJ225	CARBON 0.25W 5% 2M2Ω
R584	ERD25TJ152	CARBON 0.25W 5% 1K5Ω
R585	ERDS1TJ100	CARBON 0.5W 5% 10Ω
R587	ERD25TJ222	CARBON 0.25W 5% 2K2Ω
R588	ERD25TJ222	CARBON 0.25W 5% 2K2Ω
R589	TSF19201	FS LINK ▲
R601	ERJ6GEYJ101	S.M.CARB 0.1W 5% 100Ω
R602	ERJ6GEYJ101	S.M.CARB 0.1W 5% 100Ω
R603	ERJ6GEYJ102	S.M.CARB 0.1W 5% 1KΩ
R604	ERJ6GEYJ750	S.M.CARB 0.1W 5% 75Ω
R605	ERJ6GEYJ750	S.M.CARB 0.1W 5% 75Ω
R606	ERJ6GEYJ750	S.M.CARB 0.1W 5% 75Ω
R609	ERJ6GEYJ153	S.M.CARB 0.1W 5% 15KΩ
R610	ERJ6GEYJ823	S.M.CARB 0.1W 5% 82KΩ
R612	ERJ6GEYJ392	S.M.CARB 0.1W 5% 3K9Ω
R613	ERJ6GEYJ392	S.M.CARB 0.1W 5% 3K9Ω
R615	ERJ6GEYJ823	S.M.CARB 0.1W 5% 82KΩ
R616	ERJ6GEYJ101	S.M.CARB 0.1W 5% 100Ω
R617	ERJ6GEYJ101	S.M.CARB 0.1W 5% 100Ω
R618	ERJ6GEYJ100	S.M.CARB 0.1W 5% 10Ω
R619	ERJ6GEYOR00	S.M.CARB 0.1W 5% 0Ω
R620	ERJ6GEYOR00	S.M.CARB 0.1W 5% 0Ω
R621	ERJ6GEYOR00	S.M.CARB 0.1W 5% 0Ω
R624	ERJ6GEYJ151	S.M.CARB 0.1W 5% 150Ω
R625	ERJ6GEYJ393	S.M.CARB 0.1W 5% 39KΩ
R626	ERJ6GEYJ153	S.M.CARB 0.1W 5% 15KΩ
R627	ERJ6GEYJ681	S.M.CARB 0.1W 5% 680Ω
R628	ERJ6GEYJ151	S.M.CARB 0.1W 5% 150Ω
R629	ERJ6GEYOR00	S.M.CARB 0.1W 5% 0Ω
R630	ERJ6GEYJ560	S.M.CARB 0.1W 5% 56Ω
R632	ERJ6GEYJ393	S.M.CARB 0.1W 5% 39KΩ
R633	ERJ6GEYJ153	S.M.CARB 0.1W 5% 15KΩ
R634	ERJ6GEYJ681	S.M.CARB 0.1W 5% 680Ω
R635	ERJ6GEYJ151	S.M.CARB 0.1W 5% 150Ω
R636	ERJ6GEYOR00	S.M.CARB 0.1W 5% 0Ω
R637	ERJ6GEYJ331	S.M.CARB 0.1W 5% 330Ω
R639	EVNDXAA03B32	CONTROL 300Ω
R640	ERJ6GEYOR00	S.M.CARB 0.1W 5% 0Ω
R641	ERJ6GEYJ471	S.M.CARB 0.1W 5% 470Ω
R642	ERJ6GEYJ271	S.M.CARB 0.1W 5% 270Ω
R643	ERJ6GEYJ101	S.M.CARB 0.1W 5% 100Ω
R644	ERJ6GEYJ102	S.M.CARB 0.1W 5% 1KΩ
R645	ERJ6GEYJ271	S.M.CARB 0.1W 5% 270Ω
R646	ERJ6GEYOR00	S.M.CARB 0.1W 5% 0Ω
R647	ERJ6GEYJ151	S.M.CARB 0.1W 5% 150Ω
R648	ERJ6GEYOR00	S.M.CARB 0.1W 5% 0Ω
R649	ERJ6GEYOR00	S.M.CARB 0.1W 5% 0Ω
R651	ERJ6GEYJ225	SM.CARB0.125W 5% 2M2Ω
R652	ERJ6GEYJ103	S.M.CARB 0.1W 5% 10KΩ
R653	ERJ6GEYJ103	S.M.CARB 0.1W 5% 10KΩ
R654	ERJ6GEYJ103	S.M.CARB 0.1W 5% 10KΩ
R655	ERJ6GEYJ243	SM.CARB0.125W 5% 24KΩ
R656	ERJ6GEYJ103	S.M.CARB 0.1W 5% 10KΩ
R657	ERJ6GEYJ103	S.M.CARB 0.1W 5% 10KΩ
R658	ERJ6GEYJ103	S.M.CARB 0.1W 5% 10KΩ
R659	ERJ6GEYJ102	S.M.CARB 0.1W 5% 1KΩ
R660	ERJ6GEYJ102	S.M.CARB 0.1W 5% 1KΩ
R661	ERJ6GEYJ102	S.M.CARB 0.1W 5% 1KΩ
R663	ERJ6GEYOR00	S.M.CARB 0.1W 5% 0Ω
R664	ERC14GJ206V	SOLID 14W 5% 20MΩ
R665	ERC14GJ206V	SOLID 14W 5% 20MΩ
R666	ERJ6GEYJ101	S.M.CARB 0.1W 5% 100Ω
R667	ERJ6GEYJ101	S.M.CARB 0.1W 5% 100Ω
R668	ERJ6GEYJ101	S.M.CARB 0.1W 5% 100Ω
R711	ERJ6GEYJ224	S.M.CARB 0.1W 5% 220KΩ
R712	ERJ6GEYJ223	S.M.CARB 0.1W 5% 22KΩ
R714	ERJ6GEYJ682	S.M.CARB 0.1W 5% 6K8Ω
R715	ERJ6GEYJ222	S.M.CARB 0.1W 5% 2K2Ω

Ref No.	Part No.	Description
R716	ERJ6GEYOR00	S.M.CARB 0.1W 5% 0Ω
R717	ERJ6GEYJ153	S.M.CARB 0.1W 5% 15KΩ
R718	ERJ6GEYJ472	S.M.CARB 0.1W 5% 4K7Ω
R753	ERD25TJ333	CARBON 0.25W 5% 33KΩ
R805	232266296706	THERMISTOR
R807	ERD25TJ104	CARBON 0.25W 5% 100KΩ
R809	ERF10ZK4R7	WOUND 10W 5% 4R7Ω ▲
R810	ERD25TJ223	CARBON 0.25W 5% 22KΩ
R811	ERD25TJ391	CARBON 0.25W 5% 390Ω
R812	ERD25TJ681	CARBON 0.25W 5% 680Ω
R814	ERD25TJ332	CARBON 0.25W 5% 3K3Ω
R815	ERD25TJ150	CARBON 0.25W 5% 15Ω
R816	ERDS1TJ470	CARBON 0.5W 5% 47Ω
R818	ERD25TJ331	CARBON 0.25W 5% 330Ω
R820	ERG3FJ223	METAL 3W 5% 22KΩ ▲
R821	ERG3FJ223	METAL 3W 5% 22KΩ ▲
R822	ERD25TJ391	CARBON 0.25W 5% 390Ω
R823	ERX2SJR22	METAL 2W 5% R22Ω
R824	ERX2SJR22	METAL 2W 5% R22Ω
R825	ERX2SJR22	METAL 2W 5% R22Ω
R827	ERDS1FJ100	CARBON 0.5W 5% 10Ω
R828	ERD25TJ103	CARBON 0.25W 5% 10KΩ
R829	ERD25TJ471	CARBON 0.25W 5% 470Ω
R831	ERD75TAJ825	CARBON 0.75W 5% 8M2Ω ▲
R832	ERG1SJ331	METAL 1W 5% 330Ω ▲
R835	ERD25TJ220	CARBON 0.25W 5% 22Ω
R836	ERD25TJ100	CARBON 0.25W 5% 10Ω
R837	ERD25TJ153	CARBON 0.25W 5% 15KΩ
R838	ERD25TJ102	CARBON 0.25W 5% 1KΩ
R847	ERQ1CKPR82	METAL 1W 5% R82Ω ▲
R853	ERO25CKF1002	METAL 0.25W 1% 10KΩ ▲
R854	ERDS1TJ153	CARBON 0.5W 5% 15KΩ
R855	ERD25TJ472	CARBON 0.25W 5% 4K7Ω
R856	ERD25TJ473	CARBON 0.25W 5% 47KΩ
R858	ERO25CKF1002	METAL 0.25W 1% 10KΩ ▲
R862	ERD25TJ472	CARBON 0.25W 5% 4K7Ω
R863	ERG3FJ680	METAL 3W 5% 68Ω ▲
R864	ERDS1TJ103	CARBON 0.5W 5% 10KΩ
R865	ERG3FJ680	METAL 3W 5% 68Ω ▲
R867	ERD25TJ102	CARBON 0.25W 5% 1KΩ
R870	ERD25TJ101	CARBON 0.25W 5% 100Ω
R873	ERDS1TJ3R3	CARBON 0.5W 5% 3R3Ω
R876	ERD25TJ562	CARBON 0.25W 5% 5K6Ω
R877	ERO25CKF1052	METAL 25W 1% 10KΩ ▲
R878	ERO25CKF1002	METAL 0.25W 1% 10KΩ ▲
R883	ERD25TJ103	CARBON 0.25W 5% 10KΩ
R885	ERD25TJ103	CARBON 0.25W 5% 10KΩ
R886	ERF10ZK4R7	WOUND 10W 5% 4R7Ω ▲
R888	ERDS1TJ393	CARBON 0.5W 5% 39KΩ
R889	ERD25TJ392	CARBON 0.25W 5% 3K9Ω
R890	ERX3SJR56	METAL 3W 5% R56Ω
R891	ERD25TJ103	CARBON 0.25W 5% 10KΩ
R892	ERD25TJ222	CARBON 0.25W 5% 2K2Ω
R897	ERO25CKF1503	METAL 0.25W 1% 15Ω ▲
R898	ERO25CKF1002	METAL 0.25W 1% 10KΩ ▲
R1054	ERD25TJ101	CARBON 0.25W 5% 100Ω
R1057	ERD25TJ101	CARBON 0.25W 5% 100Ω
R1058	ERD25TJ471	CARBON 0.25W 5% 470Ω
R1059	ERD25TJ103	CARBON 0.25W 5% 10KΩ
R1061	ERD25TJ103	CARBON 0.25W 5% 10KΩ
R1062	ERD25TJ222	CARBON 0.25W 5% 2K2Ω
R1063	ERD25TJ222	CARBON 0.25W 5% 2K2Ω
R1064	ERD25TJ332	CARBON 0.25W 5% 3K3Ω
R1065	ERD25TJ512	CARBON 0.25W 5% 5K1Ω
R1066	ERD25TJ912	CARBON 0.25W 5% 9K1Ω
R1101	ERJ6GEYJ472	S.M.CARB 0.1W 5% 4K7Ω
R1102	ERJ6GEYJ472	S.M.CARB 0.1W 5% 4K7Ω
R1103	ERJ6GEYJ472	S.M.CARB 0.1W 5% 4K7Ω
R1104	ERJ6GEYJ472	S.M.CARB 0.1W 5% 4K7Ω
R1105	ERJ6GEYJ472	S.M.CARB 0.1W 5% 4K7Ω
R1106	ERJ6GEYJ472	S.M.CARB 0.1W 5% 4K7Ω

Ref No.	Part No.	Description
R1107	ERJ6GEYJ472	S.M.CARB 0.1W 5% 4K7Ω
R1108	ERJ6GEYJ472	S.M.CARB 0.1W 5% 4K7Ω
R1111	ERJ6GEYJ101	S.M.CARB 0.1W 5% 100Ω
R1112	ERJ6GEYJ101	S.M.CARB 0.1W 5% 100Ω
R1113	ERJ6GEYJ101	S.M.CARB 0.1W 5% 100Ω
R1116	ERJ6GEYJ101	S.M.CARB 0.1W 5% 100Ω
R1117	ERJ6GEYJ101	S.M.CARB 0.1W 5% 100Ω
R1118	ERJ6GEYJ101	S.M.CARB 0.1W 5% 100Ω
R1119	ERJ6GEYJ101	S.M.CARB 0.1W 5% 100Ω
R1120	ERJ6GEYJ101	S.M.CARB 0.1W 5% 100Ω
R1121	ERJ6GEYJ101	S.M.CARB 0.1W 5% 100Ω
R1122	ERJ6GEYJ101	S.M.CARB 0.1W 5% 100Ω
R1123	ERJ6GEYJ472	S.M.CARB 0.1W 5% 4K7Ω
R1124	ERJ6GEYJ103	S.M.CARB 0.1W 5% 10KΩ
R1125	ERJ6GEYJ103	S.M.CARB 0.1W 5% 10KΩ
R1126	ERJ6GEYJ101	S.M.CARB 0.1W 5% 100Ω
R1127	ERJ6GEYJ101	S.M.CARB 0.1W 5% 100Ω
R1128	ERJ6GEYJ100	S.M.CARB 0.1W 5% 10Ω
R1129	ERJ6GEYJ100	S.M.CARB 0.1W 5% 10Ω
R1133	ERJ6GEYJ103	S.M.CARB 0.1W 5% 10KΩ
R1134	ERJ6GEYJ103	S.M.CARB 0.1W 5% 10KΩ
R1135	ERJ6GEY0R00	S.M.CARB 0.1W 5% 0Ω
R1136	ERJ6GEYJ221	S.M.CARB 0.1W 5% 220Ω
R1137	ERJ6GEYJ561	S.M.CARB 0.1W 5% 560Ω
R1138	ERJ6GEYJ103	S.M.CARB 0.1W 5% 10KΩ
R1142	ERJ6GEYJ103	S.M.CARB 0.1W 5% 10KΩ
R1145	ERJ6GEYJ472	S.M.CARB 0.1W 5% 4K7Ω
R1150	ERJ6GEYJ472	S.M.CARB 0.1W 5% 4K7Ω
R1151	ERJ6GEYJ472	S.M.CARB 0.1W 5% 4K7Ω
R1152	ERJ6GEYJ472	S.M.CARB 0.1W 5% 4K7Ω
R1153	ERJ6GEYJ472	S.M.CARB 0.1W 5% 4K7Ω
R1154	ERJ6GEYJ472	S.M.CARB 0.1W 5% 4K7Ω
R1156	ERJ6GEYJ182	S.M.CARB 0.1W 5% 1K8Ω
R1163	ERJ6GEYJ152	S.M.CARB 0.1W 5% 1K5Ω
R1164	ERJ6GEYJ101	S.M.CARB 0.1W 5% 100Ω
R1169	ERJ6GEYJ102	S.M.CARB 0.1W 5% 1KΩ
R1170	ERJ6GEYJ332	S.M.CARB 0.1W 5% 3K3Ω
R1171	ERJ6GEYJ682	S.M.CARB 0.1W 5% 6K8Ω
R1172	ERJ6GEYJ561	S.M.CARB 0.1W 5% 560Ω
R1174	ERDS1TJ561	CARBON 0.5W 5% 560Ω
R1182	ERJ6GEYJ472	S.M.CARB 0.1W 5% 4K7Ω
R1183	ERJ6GEYJ472	S.M.CARB 0.1W 5% 4K7Ω
R1184	ERJ6GEYJ472	S.M.CARB 0.1W 5% 4K7Ω
R1185	ERJ6GEYJ101	S.M.CARB 0.1W 5% 100Ω
R1186	ERJ6GEYJ103	S.M.CARB 0.1W 5% 10KΩ
R1188	ERJ6GEYJ222	S.M.CARB 0.1W 5% 2K2Ω
R1190	ERJ6GEY0R00	S.M.CARB 0.1W 5% 0Ω
R1191	ERJ6GEYJ104	S.M.CARB 0.1W 5% 100KΩ
R1192	ERJ6GEYJ104	S.M.CARB 0.1W 5% 100KΩ
R1193	ERJ6GEYJ103	S.M.CARB 0.1W 5% 10KΩ
R1194	ERJ6GEYJ101	S.M.CARB 0.1W 5% 100Ω
R1301	ERJ6GEY0R00	S.M.CARB 0.1W 5% 0Ω
R1302	ERJ6GEYJ392	S.M.CARB 0.1W 5% 3K9Ω
R1305	ERJ6GEYJ560	S.M.CARB 0.1W 5% 56Ω
R1306	ERJ6GEYJ101	S.M.CARB 0.1W 5% 100Ω
R1315	ERJ6GEYJ101	S.M.CARB 0.1W 5% 100Ω
R1317	ERJ6GEYJ181	S.M.CARB 0.1W 5% 180Ω
R1318	ERJ6GEYJ181	S.M.CARB 0.1W 5% 180Ω
R1319	ERJ6GEY0R00	S.M.CARB 0.1W 5% 0Ω
R1340	ERJ6GEYJ102	S.M.CARB 0.1W 5% 1KΩ
R1504	ERJ6GEYJ121	S.M.CARB 0.1W 5% 120Ω
R1507	ERJ6GEYJ272	S.M.CARB 0.1W 5% 2K7Ω
R1508	ERJ6GEYJ121	S.M.CARB 0.1W 5% 120Ω
R1510	ERJ6GEYJ101	S.M.CARB 0.1W 5% 100Ω
R1511	ERJ6GEYJ272	S.M.CARB 0.1W 5% 2K7Ω
R1513	ERJ6GEYJ272	S.M.CARB 0.1W 5% 2K7Ω
R1515	ERJ6GEYJ471	S.M.CARB 0.1W 5% 470Ω
R1516	ERJ6GEYJ471	S.M.CARB 0.1W 5% 470Ω
R1517	ERJ6GEYJ471	S.M.CARB 0.1W 5% 470Ω
R1518	ERJ6GEYJ471	S.M.CARB 0.1W 5% 470Ω
R1519	ERJ6GEYJ471	S.M.CARB 0.1W 5% 470Ω
R1520	ERJ6GEYJ471	S.M.CARB 0.1W 5% 470Ω

Ref No.	Part No.	Description
R1523	ERJ6GEYJ101	S.M.CARB 0.1W 5% 100Ω
R1550	ERJ6GEYJ221	S.M.CARB 0.1W 5% 220Ω
R1554	ERJ6GEYJ103	S.M.CARB 0.1W 5% 10KΩ
R1555	ERJ6GEYJ331	S.M.CARB 0.1W 5% 330Ω
R1556	ERJ6GEYJ103	S.M.CARB 0.1W 5% 10KΩ
R1557	ERJ6GEYJ680	S.M.CARB 0.1W 5% 68Ω
R1559	ERJ6GEYJ560	S.M.CARB 0.1W 5% 56Ω
R1560	ERJ6GEYJ101	S.M.CARB 0.1W 5% 100Ω
R1561	ERJ6GEYJ101	S.M.CARB 0.1W 5% 100Ω
R1562	ERJ6GEYJ101	S.M.CARB 0.1W 5% 100Ω
R1564	ERJ6GEYJ101	S.M.CARB 0.1W 5% 100Ω
R1565	ERJ6GEYJ562	S.M.CARB 0.1W 5% 5K6Ω
R1566	ERJ6GEYJ392	S.M.CARB 0.1W 5% 3K9Ω
R1567	ERJ6GEYJ103	S.M.CARB 0.1W 5% 10KΩ
R1568	ERJ6GEYJ221	S.M.CARB 0.1W 5% 220Ω
R1570	ERJ6GEYJ331	S.M.CARB 0.1W 5% 330Ω
R1572	ERJ6GEY0R00	S.M.CARB 0.1W 5% 0Ω
R1575	ERJ6GEYJ391	S.M.CARB 0.1W 5% 390Ω
R1576	ERJ6GEYJ821	S.M.CARB 0.1W 5% 820Ω
R1577	ERJ6GEYJ750	S.M.CARB 0.1W 5% 75Ω
R1578	ERJ6GEYJ100	S.M.CARB 0.1W 5% 10Ω
R1581	ERJ6GEYJ223	S.M.CARB 0.1W 5% 22KΩ
R1582	ERJ6GEYJ223	S.M.CARB 0.1W 5% 22KΩ
R1583	ERJ6GEYJ560	S.M.CARB 0.1W 5% 56Ω
R1584	ERJ6GEYJ101	S.M.CARB 0.1W 5% 100Ω
R1587	ERJ6GEYJ223	S.M.CARB 0.1W 5% 22KΩ
R1605	ERJ6GEYJ101	S.M.CARB 0.1W 5% 100Ω
R1606	ERJ6GEYJ101	S.M.CARB 0.1W 5% 100Ω
R1608	ERJ6GEYJ472	S.M.CARB 0.1W 5% 4K7Ω
R1620	ERJ6GEYJ472	S.M.CARB 0.1W 5% 4K7Ω
R1621	ERJ6GEYJ101	S.M.CARB 0.1W 5% 100Ω
R1622	ERJ6GEYJ101	S.M.CARB 0.1W 5% 100Ω
R1627	ERJ6GEYJ622	S.M.CARB0.125W 5% 6K2Ω
R1628	ERJ6GEYJ161	S.M.CARB0.125W 5% 160Ω
R1629	ERJ6GEYJ201	S.M.CARB 0.1W 5% 200Ω
R1630	ERJ6GEYJ181	S.M.CARB 0.1W 5% 180Ω
R1631	ERJ6GEYJ103	S.M.CARB 0.1W 5% 10KΩ
R1632	ERJ6GEYJ133	S.M.CARB0.125W 5% 13KΩ
R1633	ERJ6GEYJ151	S.M.CARB 0.1W 5% 150Ω
R1634	ERJ6GEYJ472	S.M.CARB 0.1W 5% 4K7Ω
R1635	ERJ6GEYJ472	S.M.CARB 0.1W 5% 4K7Ω
R1636	ERJ6GEYJ561	S.M.CARB 0.1W 5% 560Ω
R1637	ERJ6GEYJ471	S.M.CARB 0.1W 5% 470Ω
R1638	ERJ6GEYJ561	S.M.CARB 0.1W 5% 560Ω
R1639	ERJ6GEYJ471	S.M.CARB 0.1W 5% 470Ω
R1641	ERJ6GEYJ471	S.M.CARB 0.1W 5% 470Ω
R1643	ERJ6GEYJ102	S.M.CARB 0.1W 5% 1KΩ
R1644	ERJ6GEYJ471	S.M.CARB 0.1W 5% 470Ω
R1646	ERJ6GEYJ331	S.M.CARB 0.1W 5% 330Ω
R1647	ERJ6GEYJ151	S.M.CARB 0.1W 5% 150Ω
R1648	ERJ6GEYJ471	S.M.CARB 0.1W 5% 470Ω
R1649	ERJ6GEYJ560	S.M.CARB 0.1W 5% 56Ω
R1650	ERJ6GEYJ471	S.M.CARB 0.1W 5% 470Ω
R1652	ERJ6GEYJ561	S.M.CARB 0.1W 5% 560Ω
R1653	ERJ6GEYJ471	S.M.CARB 0.1W 5% 470Ω
R1654	ERJ6GEYJ560	S.M.CARB 0.1W 5% 56Ω
R1656	ERJ6GEYJ102	S.M.CARB 0.1W 5% 1KΩ
R1657	ERJ6GEYJ471	S.M.CARB 0.1W 5% 470Ω
R1658	ERJ6GEYJ561	S.M.CARB 0.1W 5% 560Ω
R1659	ERJ6GEYJ560	S.M.CARB 0.1W 5% 56Ω
R1662	ERJ6GEYJ560	S.M.CARB 0.1W 5% 56Ω
R1666	ERJ6GEY0R00	S.M.CARB 0.1W 5% 0Ω
R1667	ERJ6GEYJ560	S.M.CARB 0.1W 5% 56Ω
R1668	ERJ6GEYJ560	S.M.CARB 0.1W 5% 56Ω
R1669	ERJ6GEYJ272	S.M.CARB 0.1W 5% 2K7Ω
R1670	ERJ6GEYJ272	S.M.CARB 0.1W 5% 2K7Ω
R1671	ERJ6GEYJ272	S.M.CARB 0.1W 5% 2K7Ω
R1672	ERJ6GEYJ151	S.M.CARB 0.1W 5% 150Ω
R1673	ERJ6GEYJ151	S.M.CARB 0.1W 5% 150Ω
R1674	ERJ6GEYJ221	S.M.CARB 0.1W 5% 220Ω
R1679	ERJ6GEYJ473	S.M.CARB 0.1W 5% 47KΩ
R1680	ERJ6GEYJ153	S.M.CARB 0.1W 5% 15KΩ

Ref No.	Part No.	Description			
R1681	ERJ6GEY0R00	S.M.CARB 0.1W	5%	0Ω	
R1682	ERJ6GEYJ151	S.M.CARB 0.1W	5%	150Ω	
R1683	ERJ6GEYJ151	S.M.CARB 0.1W	5%	150Ω	
R1688	ERJ6GEYJ561	S.M.CARB 0.1W	5%	560Ω	
R1701	ERJ6GEYJ472	S.M.CARB 0.1W	5%	4K7Ω	
R1702	ERJ6GEYJ101	S.M.CARB 0.1W	5%	100Ω	
R1703	ERJ6GEYJ101	S.M.CARB 0.1W	5%	100Ω	
R2001	ERJ6GEYJ473	S.M.CARB 0.1W	5%	47KΩ	
R2004	ERJ6GEYJ103	S.M.CARB 0.1W	5%	10KΩ	
R2005	ERJ6GEYJ101	S.M.CARB 0.1W	5%	100Ω	
R2006	ERJ6GEYJ101	S.M.CARB 0.1W	5%	100Ω	
R2007	ERJ6GEYJ183	S.M.CARB 0.1W	5%	18KΩ	
R2008	ERJ6GEY0R00	S.M.CARB 0.1W	5%	0Ω	
R2009	ERJ6GEY0R00	S.M.CARB 0.1W	5%	0Ω	
R2010	ERJ6GEYJ101	S.M.CARB 0.1W	5%	100Ω	
R2011	ERJ6GEYJ222	S.M.CARB 0.1W	5%	2K2Ω	
R2012	ERJ6GEYJ101	S.M.CARB 0.1W	5%	100Ω	
R2013	ERJ6GEYJ222	S.M.CARB 0.1W	5%	2K2Ω	
R2014	ERJ6GEYJ471	S.M.CARB 0.1W	5%	470Ω	
R2015	ERJ6GEYJ222	S.M.CARB 0.1W	5%	2K2Ω	
R2016	ERJ6GEYJ471	S.M.CARB 0.1W	5%	470Ω	
R2017	ERJ6GEYJ222	S.M.CARB 0.1W	5%	2K2Ω	
R2018	ERJ6GEYJ471	S.M.CARB 0.1W	5%	470Ω	
R2019	ERJ6GEYJ471	S.M.CARB 0.1W	5%	470Ω	
R2020	ERJ6GEYJ562	S.M.CARB 0.1W	5%	5K6Ω	
R2021	ERJ6GEYJ102	S.M.CARB 0.1W	5%	1KΩ	
R2022	ERJ6GEYJ471	S.M.CARB 0.1W	5%	470Ω	
R2023	ERJ6GEY0R00	S.M.CARB 0.1W	5%	0Ω	
R2025	ERJ6GEYJ123	S.M.CARB 0.1W	5%	12KΩ	
R2026	ERJ6GEYJ562	S.M.CARB 0.1W	5%	5K6Ω	
R2027	ERJ6GEYJ102	S.M.CARB 0.1W	5%	1KΩ	
R2038	ERJ6GEY0R00	S.M.CARB 0.1W	5%	0Ω	
R2039	ERJ6GEYJ471	S.M.CARB 0.1W	5%	470Ω	
R2044	ERJ6GEYJ471	S.M.CARB 0.1W	5%	470Ω	
R2045	ERJ6GEYJ471	S.M.CARB 0.1W	5%	470Ω	
R2351	ERQ14AJW100	METAL 0.25W	5%	10Ω	△
R2352	ERD25TJ101	CARBON 0.25W	5%	100Ω	
R2353	ERD25TJ101	CARBON 0.25W	5%	100Ω	
R2354	ERD25TJ473	CARBON 0.25W	5%	47KΩ	
R2355	ERD25TJ102	CARBON 0.25W	5%	1KΩ	
R2356	ERD25TJ102	CARBON 0.25W	5%	1KΩ	
R2357	ERD25TJ102	CARBON 0.25W	5%	1KΩ	
R2358	ERD25TJ102	CARBON 0.25W	5%	1KΩ	
R2359	ERD25TJ271	CARBON 0.25W	5%	270Ω	
R2360	ERD25TJ183	CARBON 0.25W	5%	18KΩ	
R2361	ERD25TJ100	CARBON 0.25W	5%	10Ω	
R2371	ERQ14AJW100	METAL 0.25W	5%	10Ω	△
R2372	ERD25TJ101	CARBON 0.25W	5%	100Ω	
R2373	ERD25TJ101	CARBON 0.25W	5%	100Ω	
R2374	ERD25TJ473	CARBON 0.25W	5%	47KΩ	
R2375	ERD25TJ102	CARBON 0.25W	5%	1KΩ	
R2376	ERD25TJ102	CARBON 0.25W	5%	1KΩ	
R2377	ERD25TJ102	CARBON 0.25W	5%	1KΩ	
R2378	ERD25TJ102	CARBON 0.25W	5%	1KΩ	
R2379	ERD25TJ271	CARBON 0.25W	5%	270Ω	
R2380	ERD25TJ183	CARBON 0.25W	5%	18KΩ	
R2381	ERD25TJ100	CARBON 0.25W	5%	10Ω	
R3006	ERJ6GEYJ750	S.M.CARB 0.1W	5%	75Ω	
R3101	ERJ6GEYJ102	S.M.CARB 0.1W	5%	1KΩ	
R3102	ERJ6GEYJ102	S.M.CARB 0.1W	5%	1KΩ	
R3107	ERJ6GEYJ104	S.M.CARB 0.1W	5%	100KΩ	
R3108	ERJ6GEYJ104	S.M.CARB 0.1W	5%	100KΩ	
R3109	ERJ6GEYJ681	S.M.CARB 0.1W	5%	680Ω	
R3110	ERJ6GEYJ681	S.M.CARB 0.1W	5%	680Ω	
R3114	ERJ6GEYJ681	S.M.CARB 0.1W	5%	680Ω	
R3115	ERJ6GEYJ104	S.M.CARB 0.1W	5%	100KΩ	
R3117	ERJ6GEYJ104	S.M.CARB 0.1W	5%	100KΩ	
R3118	ERJ6GEYJ681	S.M.CARB 0.1W	5%	680Ω	
R3126	ERJ6GEYJ102	S.M.CARB 0.1W	5%	1KΩ	
R3127	ERJ6GEYJ102	S.M.CARB 0.1W	5%	1KΩ	
R3128	ERJ6GEYJ104	S.M.CARB 0.1W	5%	100KΩ	
R3129	ERJ6GEYJ104	S.M.CARB 0.1W	5%	100KΩ	

Ref No.	Part No.	Description			
R3130	ERJ6GEYJ681	S.M.CARB 0.1W	5%	680Ω	
R3131	ERJ6GEYJ681	S.M.CARB 0.1W	5%	680Ω	
R3132	ERD2FCVVG100T	CARBON 2W	2%	10Ω	
R3133	ERJ6GEYJ101	S.M.CARB 0.1W	5%	100Ω	
R3134	ERJ6GEYJ101	S.M.CARB 0.1W	5%	100Ω	
R3135	ERJ6GEYJ101	S.M.CARB 0.1W	5%	100Ω	
R3136	ERJ6GEYJ101	S.M.CARB 0.1W	5%	100Ω	
R3137	ERJ6GEYJ750	S.M.CARB 0.1W	5%	75Ω	
R3138	ERJ6GEYJ470	S.M.CARB 0.1W	5%	47Ω	
R3139	ERJ6GEYJ101	S.M.CARB 0.1W	5%	100Ω	
R3140	ERJ6GEYJ101	S.M.CARB 0.1W	5%	100Ω	
R3141	ERJ6GEYJ101	S.M.CARB 0.1W	5%	100Ω	
R3142	ERJ6GEYJ101	S.M.CARB 0.1W	5%	100Ω	
R3143	ERJ6GEYJ333	S.M.CARB 0.1W	5%	33KΩ	
R3144	ERJ6GEYJ101	S.M.CARB 0.1W	5%	100Ω	
R3145	ERJ6GEYJ101	S.M.CARB 0.1W	5%	100Ω	
R3146	ERJ6GEYJ333	S.M.CARB 0.1W	5%	33KΩ	
R3147	ERJ6GEYJ153	S.M.CARB 0.1W	5%	15KΩ	
R3148	ERJ6GEYJ750	S.M.CARB 0.1W	5%	75Ω	
R3149	ERJ6GEYJ750	S.M.CARB 0.1W	5%	75Ω	
R3150	ERJ6GEYJ470	S.M.CARB 0.1W	5%	47Ω	
R3151	ERJ6GEYJ750	S.M.CARB 0.1W	5%	75Ω	
R3152	ERJ6GEYJ101	S.M.CARB 0.1W	5%	100Ω	
R3153	ERJ6GEYJ101	S.M.CARB 0.1W	5%	100Ω	
R3154	ERD2FCVVG100T	CARBON 2W	2%	10Ω	
R3158	ERJ6GEYJ470	S.M.CARB 0.1W	5%	47Ω	
R3159	ERJ6GEYJ681	S.M.CARB 0.1W	5%	680Ω	
R3160	ERJ6GEYJ563	S.M.CARB 0.1W	5%	56KΩ	
R3161	ERJ6GEYJ121	S.M.CARB 0.1W	5%	120Ω	
R3162	ERJ6GEYJ101	S.M.CARB 0.1W	5%	100Ω	
R3163	ERJ6GEYJ153	S.M.CARB 0.1W	5%	15KΩ	
R3165	ERJ6GEYJ103	S.M.CARB 0.1W	5%	10KΩ	
R3167	ERJ6GEYJ103	S.M.CARB 0.1W	5%	10KΩ	
R3178	ERJ6GEY0R00	S.M.CARB 0.1W	5%	0Ω	
R3180	ERJ6GEY0R00	S.M.CARB 0.1W	5%	0Ω	
R3182	ERJ6GEY0R00	S.M.CARB 0.1W	5%	0Ω	
R3184	ERJ6GEY0R00	S.M.CARB 0.1W	5%	0Ω	
R3185	ERJ6GEYJ333	S.M.CARB 0.1W	5%	33KΩ	
R3186	ERJ6GEYJ101	S.M.CARB 0.1W	5%	100Ω	
R3187	ERJ6GEYJ333	S.M.CARB 0.1W	5%	33KΩ	
R3188	ERJ6GEYJ101	S.M.CARB 0.1W	5%	100Ω	
R3192	ERJ6GEY0R00	S.M.CARB 0.1W	5%	0Ω	
R3193	ERJ6GEY0R00	S.M.CARB 0.1W	5%	0Ω	
R3194	ERJ6GEYJ750	S.M.CARB 0.1W	5%	75Ω	
R3195	ERJ6GEYJ750	S.M.CARB 0.1W	5%	75Ω	
R3196	ERJ6GEYJ470	S.M.CARB 0.1W	5%	47Ω	
R3197	ERD2FCVVG100T	CARBON 2W	2%	10Ω	
R3198	ERJ6GEYJ470	S.M.CARB 0.1W	5%	47Ω	
R3199	ERJ6GEYJ470	S.M.CARB 0.1W	5%	47Ω	
R3200	ERJ6GEYJ104	S.M.CARB 0.1W	5%	100KΩ	
R3201	ERJ6GEYJ332	S.M.CARB 0.1W	5%	3K3Ω	
R3202	ERJ6GEYJ332	S.M.CARB 0.1W	5%	3K3Ω	
R3205	ERJ6GEYJ104	S.M.CARB 0.1W	5%	100KΩ	
R3206	ERJ6GEYJ104	S.M.CARB 0.1W	5%	100KΩ	
R3207	ERJ6GEYJ104	S.M.CARB 0.1W	5%	100KΩ	
R3208	ERJ6GEYJ101	S.M.CARB 0.1W	5%	100Ω	
R3209	ERJ6GEYJ101	S.M.CARB 0.1W	5%	100Ω	
R3210	ERJ6GEYJ152	S.M.CARB 0.1W	5%	1K5Ω	
R3211	ERJ6GEYJ152	S.M.CARB 0.1W	5%	1K5Ω	
R3212	ERJ6GEYJ123	S.M.CARB 0.1W	5%	12KΩ	
R3213	ERJ6GEYJ101	S.M.CARB 0.1W	5%	100Ω	
R3214	ERJ6GEYJ153	S.M.CARB 0.1W	5%	15KΩ	
R3215	ERD2FCVVG100T	CARBON 2W	2%	10Ω	
R3216	ERJ6GEYJ680	S.M.CARB 0.1W	5%	68Ω	
R3217	ERJ6GEYJ102	S.M.CARB 0.1W	5%	1KΩ	
R3218	ERJ6GEYJ750	S.M.CARB 0.1W	5%	75Ω	
R3226	ERJ6GEYJ153	S.M.CARB 0.1W	5%	15KΩ	
R3227	ERJ6GEY0R00	S.M.CARB 0.1W	5%	0Ω	
R3228	ERJ6GEYJ680	S.M.CARB 0.1W	5%	68Ω	
R3229	ERJ6GEYJ101	S.M.CARB 0.1W	5%	100Ω	
R3230	ERJ6GEYJ102	S.M.CARB 0.1W	5%	1KΩ	
R3231	ERD2FCVVG100T	CARBON 2W	2%	10Ω	

Ref No.	Part No.	Description
R3232	ERJ6GEYJ272	S.M.CARB 0.1W 5% 2K7Ω
R3233	ERJ6GEYJ331	S.M.CARB 0.1W 5% 330Ω
R3236	ERJ6GEYJ103	S.M.CARB 0.1W 5% 10KΩ
R3237	ERJ6GEYJ103	S.M.CARB 0.1W 5% 10KΩ
R3238	ERJ6GEYJ153	S.M.CARB 0.1W 5% 15KΩ
R3239	ERJ6GEYJ153	S.M.CARB 0.1W 5% 15KΩ
R3240	ERJ6GEYJ104	S.M.CARB 0.1W 5% 100KΩ
R3501	ERJ6GEYJ100	S.M.CARB 0.1W 5% 10Ω
R3502	ERJ6GEY0R00	S.M.CARB 0.1W 5% 0Ω
R3503	ERJ6GEYJ471	S.M.CARB 0.1W 5% 470Ω
R3505	ERJ6GEYJ100	S.M.CARB 0.1W 5% 10Ω
R3506	ERJ6GEYJ100	S.M.CARB 0.1W 5% 10Ω
R3507	ERJ6GEYJ472	S.M.CARB 0.1W 5% 4K7Ω
R3508	ERJ6GEYJ151	S.M.CARB 0.1W 5% 150Ω
R3509	ERJ6GEYJ102	S.M.CARB 0.1W 5% 1KΩ
R3513	ERJ6GEYJ471	S.M.CARB 0.1W 5% 470Ω
R3514	ERJ6GEYJ471	S.M.CARB 0.1W 5% 470Ω
R3515	ERJ6GEYJ471	S.M.CARB 0.1W 5% 470Ω
R3516	ERJ6GEYJ472	S.M.CARB 0.1W 5% 4K7Ω
R3517	ERJ6GEYJ102	S.M.CARB 0.1W 5% 1KΩ
R3518	ERJ6GEY0R00	S.M.CARB 0.1W 5% 0Ω
R3520	ERJ6GEYJ221	S.M.CARB 0.1W 5% 220Ω
R3521	ERJ6GEY0R00	S.M.CARB 0.1W 5% 0Ω
R3522	ERJ6GEY0R00	S.M.CARB 0.1W 5% 0Ω
R3523	ERJ6GEY0R00	S.M.CARB 0.1W 5% 0Ω
R3526	ERD25TC0T	CARBON 0.25W 5% 0Ω
R3531	ERJ6GEYJ221	S.M.CARB 0.1W 5% 220Ω
R3532	ERJ6GEYJ391	S.M.CARB 0.1W 5% 390Ω
R3534	ERD25TJ181	CARBON 0.25W 5% 180Ω
R3536	ERJ6GEY0R00	S.M.CARB 0.1W 5% 0Ω
R3539	ERJ6GEY0R00	S.M.CARB 0.1W 5% 0Ω
R3540	ERJ6GEYJ392	S.M.CARB 0.1W 5% 3K9Ω
R3541	ERJ6GEYJ392	S.M.CARB 0.1W 5% 3K9Ω
R3542	ERJ6GEYJ392	S.M.CARB 0.1W 5% 3K9Ω
R3802	ERG3FJ100	METAL 3W 5% 10Ω ▲
R3803	ERJ6GEYJ221	S.M.CARB 0.1W 5% 220Ω
R3804	ERJ6GEYJ101	S.M.CARB 0.1W 5% 100Ω

Ref No.	Part No.	Description
SWITCHES		
S801	ESB91232A	SWITCH ▲
S1051	EVQ23405R	SWITCH
S1052	EVQ23405R	SWITCH
S1053	EVQ23405R	SWITCH
S1054	EVQ23405R	SWITCH
S1055	EVQ23405R	SWITCH
TRANSFORMERS		
T501	TLHA003	TRANSFORMER
T551	ZTFH65013A	F.B.T. ▲
T801	ETP35KAN615U	TRANSFORMER ▲
T802	ETS49AH137ND	TRANSFORMER
T803	ETQ19K55AY	TRANSFORMER
FILTERS		
X101	EFCT6504BF	FILTER
X102	EFCT5M7MW3	FILTER
X103	EFCT6R0MW5	FILTER
X104	K3953-M100	SAW FILTER
X105	K9456M	SAW FILTER
X106	EFCV3195T6	CERAMIC FILTER
X107	EFCT7004BF	CERAMIC FILTER
X109	EFCV4045T4	CERAMIC FILTER
X601	TSSA024	CRYSTAL
X602	TSSA025	CRYSTAL
X1551	TSSA009	CRYSTAL
X2001	4730007158	CRYSTAL
X3501	TSSA009	CRYSTAL

NOTE:

For models with the dark walnut finish please refer to the /A Miscellaneous Components Difference Lists and for Models with the light mahogany please refer to the /B Miscellaneous Components Difference Lists

DIFFERENCES FOR MODEL TX-28XD60P

Ref No.	Part No.	Description	
MISCELLANEOUS COMPONENTS			
4)	TNPA0292AF	Y P.C.B.	△
5)	TLK8E05125	DEGAUSS COIL	△
7)	A66ECF61X71	CRT	△
8)	TKY8E161	CABINET	△
9)	TKP8E1169	SPEAKER NET	
10)	TBX8E040	POWER BUTTON BLACK	
11)	TKP8E1175	LEFT PANEL BLACK	
12)	TKP8E1172	TOP PANEL BLACK	
14)	TQF8E2541	MODEL LABEL	
15)	TKU8E00320	BACK COVER	△
16)	TNPA0295AJ	D P.C.B.	△
20)	TNPH0063BM	E P.C.B.	△
26)	TKP8E1199	RIGHT PANEL BLACK	
27)	TKP8E1170	DOOR LID BLACK	
	TPC8E4587	OUTER CARTON	
	TPD8E633	CUSHION TOP	
	TPD8E634	CUSHION BOTTOM	
	TQB8E2407N	ROMANIAN INST BOOK	△
	TQB8E2407P	POLISH INST BOOK	△
	TQB8E2407Q	HUNGARIAN INST BOOK	△
	TQB8E2407R	CZECH INST BOOK	△
	TQB8E2407U	ENGLISH INST BOOK	△
	TQA8E2048	SCHEMATIC BROADSHEET	△

DIFFERENCES FOR MODEL TX-28XD60P/A**MISCELLANEOUS COMPONENTS**

10)	TBX8E045	POWER BUTTON DARK WOOD	
11)	TKP8E1184	LEFT PANEL DARK WOOD	
12)	TKP8E1182	TOP PANEL DARK WOOD	
14)	TQF8E2542	MODEL LABEL	
26)	TKP8E1203	RIGHT PANEL DARK WOOD	
27)	TKP8E1180	DOOR LID DARK WOOD	

DIFFERENCES FOR MODEL TX-28XD60P/B**MISCELLANEOUS COMPONENTS**

10)	TBX8E046	POWER BUTTON LIGHT WOOD	
11)	TKP8E1185	LEFT PANEL LIGHT WOOD	
12)	TKP8E1183	TOP PANEL LIGHT WOOD	
14)	TQF8E2543	MODEL LABEL	
26)	TKP8E1188	RIGHT PANEL LIGHT WOOD	
27)	TKP8E1181	DOOR LID LIGHT WOOD	

INTEGRATED CIRCUITS

IC1104	X24C0301TN	EAROM	
IC1105	27C2001505AB	EPROM	
IC2001	MSP3410DPPB4	AUDIO PROCESSOR	

Ref No.	Part No.	Description	
CAPACITORS			
C352	ECUV1H224ZFX	S.M.CAP 50V 0.22 μ F	
C353	ECUV1H103KBX	S.M.CAP 50V 10nF	
C354	ECKC2H103J	CERAMIC 50V 10nF	△
C355	ECKC2H102J	CERAMIC 500V 1nF	△
C362	ECUV1H224ZFX	S.M.CAP 50V 0.22 μ F	
C363	ECUV1H103KBX	S.M.CAP 50V 10nF	
C364	ECKC2H103J	CERAMIC 50V 10nF	△
C365	ECKC2H102J	CERAMIC 500V 1nF	△
C372	ECUV1H224ZFX	S.M.CAP 50V 0.22 μ F	
C373	ECUV1H103KBX	S.M.CAP 50V 10nF	
C374	ECKC2H103J	CERAMIC 50V 10nF	△
C375	ECKC2H102J	CERAMIC 500V 1nF	△
C381	ECA1HM101GB	ELECT 50V 100pF	
C382	ECA1CM471GB	ELECT 16V 470pF	
C383	ECUV1H103KBX	S.M.CAP 50V 10nF	
C384	ECQM2104KZ	FILM 250V 100nF	
C385	ECEA2EU220	ELECT 250V 22 μ F	
C386	ECKC3D152J	CERAMIC 2KV 1.5nF	△
C395	ECQM1H104J	FILM 50V 100nF	
C901	ECUV1H030CCX	S.M.CAP 50V 30pF	
C902	ECA1VM101GB	ELECT 35V 100pF	
C903	ECKC1H103JB	CERAMIC 50V 10nF	
C904	ECUV1H103ZFX	S.M.CAP 50V 10nF	
C905	ECA1CM100GB	ELECT 16V 10pF	
C906	ECUV1H102KBX	S.M.CAP 50V 1nF	
C908	ECUV1H151JCX	S.M.CAP 50V 150pF	
C909	ECKC2H472J	CERAMIC 500V 4.7nF	△
C910	ECKC2H472J	CERAMIC 500V 4.7nF	△
C911	ECUV1H151JCX	S.M.CAP 50V 150pF	
C912	ECEA2EU220	ELECT 250V 22 μ F	
C913	ECA1HM101GB	ELECT 50V 100pF	
C914	ECA1HM101GB	ELECT 50V 100pF	
C915	ECA1CM471GB	ELECT 16V 470pF	
C916	ECEA2EU220	ELECT 250V 22 μ F	
C917	ECA1HM100GB	ELECT 50V 10pF	
C918	ECUV1H103ZFX	S.M.CAP 50V 10nF	
C919	ECCR2H680J	CERAMIC 500V 68pF	
C2019	ECA1CM221GB	ELECT 16V 220pF	
C3351	ECA1HM101GB	ELECT 50V 100pF	

DIODES

D351	ERA15-04V3	COIL	
D352	ERA15-04V3	COIL	
D361	ERA15-04V3	COIL	
D362	ERA15-04V3	COIL	
D371	ERA15-04V3	COIL	
D372	ERA15-04V3	COIL	
D387	MA2160LFS	DIODE	
D901	1SS254T-77	DIODE	
D902	1SS254T-77	DIODE	
D903	1SS254T-77	DIODE	
D2008	ERD25TCOT	CARBON 0.25W 5% 0 Ω	
D3351	1SS254T-77	DIODE	

Ref No.	Part No.	Description
TERMINALS AND LINKS		
JSE068	ERJ6GEY0R00	S.M.CARB 0.1W 5% 0Ω
JSE072	ERJ6GEY0R00	S.M.CARB 0.1W 5% 0Ω
COILS		
L001	ERD25TC0T	CARBON 0.25W 5% 0Ω
L351	SDL5000	DELAY LINE
L352	EXCELDR25V	COIL
L353	TLT150K991R	COIL
L361	SDL5000	DELAY LINE
L362	EXCELDR25V	COIL
L363	TLT150K991R	COIL
L371	SDL5000	DELAY LINE
L372	EXCELDR25V	COIL
L373	TLT150K991R	COIL
L381	TLT220K991R	COIL
TRANSISTORS		
Q901	BC847B	TRANSISTOR OR 2SD601ATX
Q902	BC847B	TRANSISTOR OR 2SD601ATX
Q903	BC847B	TRANSISTOR OR 2SD601ATX
Q904	BC857B	TRANSISTOR OR 2SB709ATX
Q905	BC847B	TRANSISTOR OR 2SD601ATX
Q906	BC847B	TRANSISTOR OR 2SD601ATX
Q907	BC857B	TRANSISTOR OR 2SB709ATX
Q908	2SA1535ARLB	TRANSISTOR
Q909	2SC3944ARLB	TRANSISTOR
Q3351	BC847B	TRANSISTOR OR 2SD601ATX
Q3352	BC857B	TRANSISTOR OR 2SB709ATX
RESISTOR		
R350	ERQ12AJ151P	FUSIBLE 12W 5% 150Ω ▲
R351	ERJ6GEYJ102	S.M.CARB 0.1W 5% 1KΩ
R352	ERJ6GEYJ102	S.M.CARB 0.1W 5% 1KΩ
R354	ERJ6GEYJ102	S.M.CARB 0.1W 5% 1KΩ
R355	ERG2FJ823	METAL 2W 5% 82KΩ ▲
R356	ERJ6GEY0R00	S.M.CARB 0.1W 5% 0Ω
R357	ERJ6GEYJ822	S.M.CARB 0.1W 5% 8K2Ω
R358	ERDS1TJ821	CARBON 0.5W 5% 820Ω
R359	ERJ6GEYJ334	S.M.CARB 0.1W 5% 330KΩ
R360	ERDS1TJ103	CARBON 0.5W 5% 10KΩ
R361	ERJ6GEYJ102	S.M.CARB 0.1W 5% 1KΩ
R362	ERJ6GEYJ102	S.M.CARB 0.1W 5% 1KΩ
R364	ERJ6GEYJ102	S.M.CARB 0.1W 5% 1KΩ
R365	ERG2FJ823	METAL 2W 5% 82KΩ ▲
R366	ERJ6GEY0R00	S.M.CARB 0.1W 5% 0Ω
R367	ERJ6GEYJ822	S.M.CARB 0.1W 5% 8K2Ω
R368	ERDS1TJ821	CARBON 0.5W 5% 820Ω
R369	ERJ6GEY0R00	S.M.CARB 0.1W 5% 0Ω
R371	ERJ6GEYJ102	S.M.CARB 0.1W 5% 1KΩ

Ref No.	Part No.	Description
R372	ERJ6GEYJ102	S.M.CARB 0.1W 5% 1KΩ
R374	ERJ6GEYJ102	S.M.CARB 0.1W 5% 1KΩ
R375	ERG2FJ823	METAL 2W 5% 82KΩ ▲
R376	ERJ6GEY0R00	S.M.CARB 0.1W 5% 0Ω
R377	ERJ6GEYJ822	S.M.CARB 0.1W 5% 8K2Ω
R378	ERDS1TJ821	CARBON 0.5W 5% 820Ω
R379	ERJ6GEY0R00	S.M.CARB 0.1W 5% 0Ω
R380	ERJ6GEYJ222	S.M.CARB 0.1W 5% 2K2Ω
R381	ERJ6GEYJ561	S.M.CARB 0.1W 5% 560Ω
R383	ERJ6GEYJ562	S.M.CARB 0.1W 5% 5K6Ω
R385	ERQ12HKR39	METAL 0.5W 5% R39Ω ▲
R390	ERDS1TJ184	CARBON 0.5W 5% 180KΩ
R462	ERX2SJ1R0	METAL 2W 5% 1Ω
R558	ERD50PKF4532	METAL 50W 1% 45KΩ ▲
R905	ERJ6GEYJ681	S.M.CARB 0.1W 5% 680Ω
R906	ERJ6GEYJ393	S.M.CARB 0.1W 5% 39KΩ
R907	ERJ6GEYJ822	S.M.CARB 0.1W 5% 8K2Ω
R908	ERJ6GEYJ471	S.M.CARB 0.1W 5% 470Ω
R909	ERJ6GEYJ102	S.M.CARB 0.1W 5% 1KΩ
R910	ERJ6GEYJ221	S.M.CARB 0.1W 5% 220Ω
R911	ERD25TJ561	CARBON 0.25W 5% 560Ω
R913	ERJ6GEYJ153	S.M.CARB 0.1W 5% 15KΩ
R914	ERJ6GEYJ222	S.M.CARB 0.1W 5% 2K2Ω
R915	ERJ6GEYJ681	S.M.CARB 0.1W 5% 680Ω
R916	ERJ6GEYJ331	S.M.CARB 0.1W 5% 330Ω
R918	ERJ6GEYJ101	S.M.CARB 0.1W 5% 100Ω
R919	ERQ14AJW390	FUSIBLE 14W 5% 39Ω ▲
R920	ERQ14AJW390	FUSIBLE 14W 5% 39Ω ▲
R922	ERD25TJ683	CARBON 0.25W 5% 68KΩ
R923	ERD25TJ683	CARBON 0.25W 5% 68KΩ
R924	ERDS1FYJ390	CARBON 0.5W 5% 39Ω ▲
R925	ERJ6GEY0R00	S.M.CARB 0.1W 5% 0Ω
R926	ERJ6GEY0R00	S.M.CARB 0.1W 5% 0Ω
R927	ERD25TJ122	CARBON 0.25W 5% 1K2Ω
R928	ERD25TJ2R7	CARBON 0.25W 5% 2R7Ω
R929	ERDS1FYJ221	CARBON 0.5W 5% 220Ω
R930	ERD25TJ2R7	CARBON 0.25W 5% 2R7Ω
R931	ERDS1FYJ390	CARBON 0.5W 5% 39Ω ▲
R932	ERDS1FYJ101	CARBON 0.5W 5% 100Ω ▲
R933	ERJ6GEYJ223	S.M.CARB 0.1W 5% 22KΩ
R934	ERJ6GEYJ472	S.M.CARB 0.1W 5% 4K7Ω
R935	ERQ14AJW3R9	FUSIBLE 14W 5% 3R9Ω ▲
R936	ERQ1CJP102	METAL 1W 5% 1KΩ ▲
R937	ERQ14AJW100	METAL 0.25W 5% 10Ω ▲
R938	ERD25TJ122	CARBON 0.25W 5% 1K2Ω
R940	ERD25TJ3R3	CARBON 0.25W 5% 3R3Ω
R941	ERD25TJ3R3	CARBON 0.25W 5% 3R3Ω
R3351	ERJ6GEYJ101	S.M.CARB 0.1W 5% 100Ω
R3352	ERJ6GEYJ472	S.M.CARB 0.1W 5% 4K7Ω
R3353	ERJ6GEYJ474	S.M.CARB 0.1W 5% 470KΩ
R3354	ERJ6GEYJ102	S.M.CARB 0.1W 5% 1KΩ
R3355	ERJ6GEYJ391	S.M.CARB 0.1W 5% 390Ω
FILTERS		
X1101	TAF10020	CRYSTAL

DIFFERENCES FOR MODEL TX-25XD60P

Ref No.	Part No.	Description	
MISCELLANEOUS COMPONENTS			
4)	TNPA0292AP	Y P.C.B.	△
5)	TLK8E05120	DEGAUSS COIL	△
7)	A59ECF50X71	CRT	△
8)	TKY8E151-2	CABINET	△
9)	TKP8E1168	SPEAKER NET	
10)	TBX8E040	POWER BUTTON BLACK	
11)	TKP8E1173	LEFT PANEL BLACK	
12)	TKP8E1171	TOP PANEL BLACK	
14)	TQF8E2536	MODEL LABEL	
15)	TKU8E00310	BACK COVER	△
16)	TNPA0295AS	D P.C.B.	△
20)	TNPH0063BK	E P.C.B.	△
26)	TKP8E1201	RIGHT PANEL BLACK	
27)	TKP8E1170	DOOR LID BLACK	
	TPC8E4613	OUTER CARTON	
	TPD8E631	TOP CUSHION	
	TPD8E632	BOTTOM CUSHION	
	TQB8E2407N	ROMANIAN INST BOOK	△
	TQB8E2407P	POLISH INST BOOK	△
	TQB8E2407Q	HUNGARIAN INST BOOK	△
	TQB8E2407R	CZECH INST BOOK	△
	TQB8E2407U	ENGLISH INST BOOK	△
	TQA8E2048	SCHEMATIC BROADSHEET	△

DIFFERENCES FOR MODEL TX-25XD60P/A

MISCELLANEOUS COMPONENTS

10)	TBX8E045	POWER BUTTON DARRK WOOD
11)	TKP8E1192	LEFT PANEL DARK WOOD
12)	TKP8E1190	TOP PANEL DARK WOOD
14)	TQF8E2537	MODEL LABEL
26)	TKP8E1202	RIGHT PANEL DARK WOOD
27)	TKP8E1180	DOOR LID DARK WOOD

DIFFERENCES FOR MODEL TX-25XD60P/B

MISCELLANEOUS COMPONENTS

10)	TBX8E046	POWER BUTTON LIGHT WOOD
11)	TKP8E1193	LEFT PANEL LIGHT WOOD
12)	TKP8E1191	TOP PANEL LIGHT WOOD
14)	TQF8E2538	MODEL LABEL
26)	TKP8E1196	RIGHT PANEL LIGHT WOOD
27)	TKP8E1181	DOOR LID LIGHT WOOD

INTEGRATED CIRCUITS

IC1104	X24C0301TM	EAROM
IC1105	27C2001505AA	EPR0M
IC2001	MSP3410DPPB4	AUDIO PROCESSOR

CAPACITORS

C352	ECUV1H224ZFX	S.M.CAP	50V	0.22 μ F	
C353	ECUV1H103KBX	S.M.CAP	50V	10nF	
C354	ECKC2H103J	CERAMIC	50V	10nF	△
C355	ECKC2H102J	CERAMIC	500V	1nF	△
C362	ECUV1H224ZFX	S.M.CAP	50V	0.22 μ F	
C363	ECUV1H103KBX	S.M.CAP	50V	10nF	
C364	ECKC2H103J	CERAMIC	50V	10nF	△

Ref No.	Part No.	Description	
C365	ECKC2H102J	CERAMIC	500V 1nF △
C372	ECUV1H224ZFX	S.M.CAP	50V 0.22 μ F
C373	ECUV1H103KBX	S.M.CAP	50V 10nF
C374	ECKC2H103J	CERAMIC	50V 10nF △
C375	ECKC2H102J	CERAMIC	500V 1nF △
C381	ECA1HM101GB	ELECT	50V 100pF
C382	ECA1CM471GB	ELECT	16V 470pF
C383	ECUV1H103KBX	S.M.CAP	50V 10nF
C384	ECQM2104KZ	FILM	250V 100nF
C385	ECEA2EU220	ELECT	250V 22 μ F
C386	ECKC3D152J	CERAMIC	2KV 1.5nF △
C395	ECQM1H104J	FILM	50V 100nF
C901	ECUV1H030CCX	S.M.CAP	50V 30pF
C902	ECA1VM101GB	ELECT	35V 100pF
C903	ECKC1H103JB	CERAMIC	50V 10nF
C904	ECUV1H103ZFX	S.M.CAP	50V 10nF
C905	ECA1CM100GB	ELECT	16V 10pF
C906	ECUV1H102KBX	S.M.CAP	50V 1nF
C908	ECUV1H151JCX	S.M.CAP	50V 150pF
C909	ECKC2H472J	CERAMIC	500V 4.7nF △
C910	ECKC2H472J	CERAMIC	500V 4.7nF △
C911	ECUV1H151JCX	S.M.CAP	50V 150pF
C912	ECEA2EU220	ELECT	250V 22 μ F
C913	ECA1HM101GB	ELECT	50V 100pF
C914	ECA1HM101GB	ELECT	50V 100pF
C915	ECA1CM471GB	ELECT	16V 470pF
C916	ECEA2EU220	ELECT	250V 22 μ F
C917	ECA1HM100GB	ELECT	50V 10pF
C918	ECUV1H103ZFX	S.M.CAP	50V 10nF
C919	ECCR2H680J	CERAMIC	500V 68pF
C2019	ECA1CM221GB	ELECT	16V 220pF
C3351	ECA1HM101GB	ELECT	50V 100pF

DIODES

D351	ERA15-04V3	COIL
D352	ERA15-04V3	COIL
D361	ERA15-04V3	COIL
D362	ERA15-04V3	COIL
D371	ERA15-04V3	COIL
D372	ERA15-04V3	COIL
D387	MA2160LFS	DIODE
D901	1SS254T-77	DIODE
D902	1SS254T-77	DIODE
D903	1SS254T-77	DIODE
D3351	1SS254T-77	DIODE

FUSES

F531	ERX2FJ1R0H	METAL	2W	5%	1R0 Ω
------	------------	-------	----	----	--------------

TERMINALS AND LINKS

JSE028	ERJ6GEY0R00	S.M.CARB	0.1W	5%	0 Ω
--------	-------------	----------	------	----	------------

COILS

L351	SDL5000	DELAY LINE
L352	EXCELDR25V	COIL
L353	TLT150K991R	COIL
L361	SDL5000	DELAY LINE
L362	EXCELDR25V	COIL
L363	TLT150K991R	COIL
L371	SDL5000	DELAY LINE
L372	EXCELDR25V	COIL

Ref No.	Part No.	Description
L373	TLT150K991R	COIL
L381	TLT220K991R	COIL
TRANSISTORS		
Q901	BC847B	TRANSISTOR OR 2SD601ATX
Q902	BC847B	TRANSISTOR OR 2SD601ATX
Q903	BC847B	TRANSISTOR OR 2SD601ATX
Q904	BC857B	TRANSISTOR OR 2SB709ATX
Q905	BC847B	TRANSISTOR OR 2SD601ATX
Q906	BC847B	TRANSISTOR OR 2SD601ATX
Q907	BC857B	TRANSISTOR OR 2SB709ATX
Q908	2SA1535ARLB	TRANSISTOR
Q909	2SC3944ARLB	TRANSISTOR
Q3351	BC847B	TRANSISTOR OR 2SD601ATX
Q3352	BC857B	TRANSISTOR OR 2SB709ATX
RESISTOR		
R350	ERQ12AJ151P	FUSIBLE 12W 5% 150Ω Δ
R351	ERJ6GEYJ102	S.M.CARB 0.1W 5% 1KΩ
R352	ERJ6GEYJ102	S.M.CARB 0.1W 5% 1KΩ
R354	ERJ6GEYJ102	S.M.CARB 0.1W 5% 1KΩ
R355	ERG2FJ823	METAL 2W 5% 82KΩ Δ
R356	ERJ6GEY0R00	S.M.CARB 0.1W 5% 0Ω
R357	ERJ6GEYJ822	S.M.CARB 0.1W 5% 8K2Ω
R358	ERDS1TJ821	CARBON 0.5W 5% 820Ω
R359	ERJ6GEYJ334	S.M.CARB 0.1W 5% 330KΩ
R360	ERDS1TJ103	CARBON 0.5W 5% 10KΩ
R361	ERJ6GEYJ102	S.M.CARB 0.1W 5% 1KΩ
R362	ERJ6GEYJ102	S.M.CARB 0.1W 5% 1KΩ
R364	ERJ6GEYJ102	S.M.CARB 0.1W 5% 1KΩ
R365	ERG2FJ823	METAL 2W 5% 82KΩ Δ
R366	ERJ6GEY0R00	S.M.CARB 0.1W 5% 0Ω
R367	ERJ6GEYJ822	S.M.CARB 0.1W 5% 8K2Ω
R368	ERDS1TJ821	CARBON 0.5W 5% 820Ω
R369	ERJ6GEY0R00	S.M.CARB 0.1W 5% 0Ω
R371	ERJ6GEYJ102	S.M.CARB 0.1W 5% 1KΩ
R372	ERJ6GEYJ102	S.M.CARB 0.1W 5% 1KΩ
R374	ERJ6GEYJ102	S.M.CARB 0.1W 5% 1KΩ
R375	ERG2FJ823	METAL 2W 5% 82KΩ Δ
R376	ERJ6GEY0R00	S.M.CARB 0.1W 5% 0Ω
R377	ERJ6GEYJ822	S.M.CARB 0.1W 5% 8K2Ω
R378	ERDS1TJ821	CARBON 0.5W 5% 820Ω
R379	ERJ6GEY0R00	S.M.CARB 0.1W 5% 0Ω
R380	ERJ6GEYJ222	S.M.CARB 0.1W 5% 2K2Ω

Ref No.	Part No.	Description
R381	ERJ6GEYJ561	S.M.CARB 0.1W 5% 560Ω
R383	ERJ6GEYJ562	S.M.CARB 0.1W 5% 5K6Ω
R385	ERQ12HKR39	METAL 0.5W 5% R39Ω Δ
R390	ERDS1TJ184	CARBON 0.5W 5% 180KΩ
R558	ERD25TJ823	CARBON 0.25W 5% 82KΩ
R905	ERJ6GEYJ681	S.M.CARB 0.1W 5% 680Ω
R906	ERJ6GEYJ393	S.M.CARB 0.1W 5% 39KΩ
R907	ERJ6GEYJ822	S.M.CARB 0.1W 5% 8K2Ω
R908	ERJ6GEYJ471	S.M.CARB 0.1W 5% 470Ω
R909	ERJ6GEYJ102	S.M.CARB 0.1W 5% 1KΩ
R910	ERJ6GEYJ221	S.M.CARB 0.1W 5% 220Ω
R911	ERD25TJ561	CARBON 0.25W 5% 560Ω
R913	ERJ6GEYJ153	S.M.CARB 0.1W 5% 15KΩ
R914	ERJ6GEYJ222	S.M.CARB 0.1W 5% 2K2Ω
R915	ERJ6GEYJ681	S.M.CARB 0.1W 5% 680Ω
R916	ERJ6GEYJ331	S.M.CARB 0.1W 5% 330Ω
R918	ERJ6GEYJ101	S.M.CARB 0.1W 5% 100Ω
R919	ERQ14AJW390	FUSIBLE 14W 5% 39Ω Δ
R920	ERQ14AJW390	FUSIBLE 14W 5% 39Ω Δ
R922	ERD25TJ683	CARBON 0.25W 5% 68KΩ
R923	ERD25TJ683	CARBON 0.25W 5% 68KΩ
R924	ERDS1FYJ390	CARBON 0.5W 5% 39Ω Δ
R925	ERJ6GEY0R00	S.M.CARB 0.1W 5% 0Ω
R926	ERJ6GEY0R00	S.M.CARB 0.1W 5% 0Ω
R927	ERD25TJ122	CARBON 0.25W 5% 1K2Ω
R928	ERD25TJ2R7	CARBON 0.25W 5% 2R7Ω
R929	ERDS1FYJ221	CARBON 0.5W 5% 220Ω
R930	ERD25TJ2R7	CARBON 0.25W 5% 2R7Ω
R931	ERDS1FYJ390	CARBON 0.5W 5% 39Ω Δ
R932	ERDS1FYJ101	CARBON 0.5W 5% 100Ω Δ
R933	ERJ6GEYJ223	S.M.CARB 0.1W 5% 22KΩ
R934	ERJ6GEYJ472	S.M.CARB 0.1W 5% 4K7Ω
R935	ERQ14AJW3R9	FUSIBLE 14W 5% 3R9Ω Δ
R936	ERQ1CJP102	METAL 1W 5% 1KΩ Δ
R937	ERQ14AJW100	METAL 0.25W 5% 10Ω Δ
R938	ERD25TJ122	CARBON 0.25W 5% 1K2Ω
R940	ERD25TJ3R3	CARBON 0.25W 5% 3R3Ω
R941	ERD25TJ3R3	CARBON 0.25W 5% 3R3Ω
R3351	ERJ6GEYJ101	S.M.CARB 0.1W 5% 100Ω
R3352	ERJ6GEYJ472	S.M.CARB 0.1W 5% 4K7Ω
R3353	ERJ6GEYJ474	S.M.CARB 0.1W 5% 470KΩ
R3354	ERJ6GEYJ102	S.M.CARB 0.1W 5% 1KΩ
R3355	ERJ6GEYJ391	S.M.CARB 0.1W 5% 390Ω
FILTERS		
X1101	TAF10020	CRYSTAL

DIFFERENCES FOR MODEL TX-28XD60S

Ref No.	Part No.	Description	
MISCELLANEOUS COMPONENTS			
4)	TNPA0292AF	Y P.C.B.	△
5)	TLK8E05125	DEGAUSS COIL	△
7)	A66ECF61X71	CRT	△
8)	TKY8E161	CABINET	△
9)	TKP8E1169	SPEAKER NET	
10)	TBX8E040	POWER BUTTON BLACK	
11)	TKP8E1175	LEFT PANEL BLACK	
12)	TKP8E1172	TOP PANEL BLACK	
14)	TQF8E2550	MODEL LABEL	
15)	TKU8E00320	BACK COVER	△
16)	TNPA0295AJ	D P.C.B.	△
20)	TNPH0063BN	E P.C.B.	△
26)	TKP8E1199	RIGHT PANEL BLACK	
27)	TKP8E1170	DOOR LID BLACK	
	TPC8E4587	OUTER CARTON	
	TPD8E633	CUSHION TOP	
	TPD8E634	CUSHION BOTTOM	
	TQB8E2415L	RUSSIAN INST BOOK	△
	TQB8E2415M	BULGARIAN INST BOOK	△
	TQB8E2415U	ENGLISH INST BOOK	△
DIFFERENCES FOR MODEL TX-28XD60S/A			
MISCELLANEOUS COMPONENTS			
10)	TBX8E045	POWER BUTTON DARK WOOD	
11)	TKP8E1184	LEFT PANEL DARK WOOD	
12)	TKP8E1182	TOP PANEL DARK WOOD	
14)	TQF8E2551	MODEL LABEL	
26)	TKP8E1203	RIGHT PANEL DARK WOOD	
27)	TKP8E1180	DOOR LID DARK WOOD	
DIFFERENCES FOR MODEL TX-28XD60S/B			
MISCELLANEOUS COMPONENTS			
10)	TBX8E046	POWER BUTTON LIGHT WOOD	
11)	TKP8E1185	LEFT PANEL LIGHT WOOD	
12)	TKP8E1183	TOP PANEL LIGHT WOOD	
14)	TQF8E2552	MODEL LABEL	
26)	TKP8E1188	RIGHT PANEL LIGHT WOOD	
27)	TKP8E1181	DOOR LID LIGHT WOOD	
INTEGRATED CIRCUITS			
IC1104	X24C0301VN	EAROM	
IC1105	27C2001405AB	EPROM	
IC2001	MSP3400CPPC6	AUDIO PROCESSOR	
CAPACITORS			
C352	ECUV1H224ZFX	S.M.CAP 50V 0.22μF	
C353	ECUV1H103KBX	S.M.CAP 50V 10nF	
C354	ECKC2H103J	CERAMIC 50V 10nF	△
C355	ECKC2H102J	CERAMIC 500V 1nF	△
C362	ECUV1H224ZFX	S.M.CAP 50V 0.22μF	
C363	ECUV1H103KBX	S.M.CAP 50V 10nF	
C364	ECKC2H103J	CERAMIC 50V 10nF	△
C365	ECKC2H102J	CERAMIC 500V 1nF	△
C372	ECUV1H224ZFX	S.M.CAP 50V 0.22μF	

Ref No.	Part No.	Description	
C373	ECUV1H103KBX	S.M.CAP 50V 10nF	
C374	ECKC2H103J	CERAMIC 50V 10nF	△
C375	ECKC2H102J	CERAMIC 500V 1nF	△
C381	ECA1HM101GB	ELECT 50V 100μF	
C382	ECA1CM471GB	ELECT 16V 470μF	
C383	ECUV1H103KBX	S.M.CAP 50V 10nF	
C384	ECQM2104KZ	FILM 250V 100nF	
C385	ECEA2EU220	ELECT 250V 22μF	
C386	ECKC3D152J	CERAMIC 2KV 1.5nF	△
C395	ECQM1H104J	FILM 50V 100nF	
C901	ECUV1H030CCX	S.M.CAP 50V 30pF	
C902	ECA1VM101GB	ELECT 35V 100μF	
C903	ECKC1H103JB	CERAMIC 50V 10nF	
C904	ECUV1H103ZFX	S.M.CAP 50V 10nF	
C905	ECA1CM100GB	ELECT 16V 10μF	
C906	ECUV1H102KBX	S.M.CAP 50V 1nF	
C908	ECUV1H151JCX	S.M.CAP 50V 150pF	
C909	ECKC2H472J	CERAMIC 500V 4.7nF	△
C910	ECKC2H472J	CERAMIC 500V 4.7nF	△
C911	ECUV1H151JCX	S.M.CAP 50V 150pF	
C912	ECEA2EU220	ELECT 250V 22μF	
C913	ECA1HM101GB	ELECT 50V 100μF	
C914	ECA1HM101GB	ELECT 50V 100μF	
C915	ECA1CM471GB	ELECT 16V 470μF	
C916	ECEA2EU220	ELECT 250V 22μF	
C917	ECA1HM100GB	ELECT 50V 10μF	
C918	ECUV1H103ZFX	S.M.CAP 50V 10nF	
C919	ECCR2H680J	CERAMIC 500V 68pF	
C2019	ECA1HM101GB	ELECT 50V 100μF	
C3351	ECA1HM101GB	ELECT 50V 100μF	
DIODES			
D351	ERA15-04V3	COIL	
D352	ERA15-04V3	COIL	
D361	ERA15-04V3	COIL	
D362	ERA15-04V3	COIL	
D371	ERA15-04V3	COIL	
D372	ERA15-04V3	COIL	
D387	MA2160LFS	DIODE	
D901	1SS254T-77	DIODE	
D902	1SS254T-77	DIODE	
D903	1SS254T-77	DIODE	
D3351	1SS254T-77	DIODE	
TERMINALS AND LINKS			
JSE028	ERJ6GEY0R00	S.M.CARB 0.1W 5% ΩΩ	
COILS			
L351	SDL5000	DELAY LINE	
L352	EXCELDR25V	COIL	
L353	TLT150K991R	COIL	
L361	SDL5000	DELAY LINE	
L362	EXCELDR25V	COIL	
L363	TLT150K991R	COIL	
L371	SDL5000	DELAY LINE	
L372	EXCELDR25V	COIL	
L373	TLT150K991R	COIL	
L381	TLT220K991R	COIL	
L2002	TLT100K991R	COIL	
TRANSISTORS			

Ref No.	Part No.	Description
Q901	BC847B	TRANSISTOR OR 2SD601ATX
Q902	BC847B	TRANSISTOR OR 2SD601ATX
Q903	BC847B	TRANSISTOR OR 2SD601ATX
Q904	BC857B	TRANSISTOR OR 2SB709ATX
Q905	BC847B	TRANSISTOR OR 2SD601ATX
Q906	BC847B	TRANSISTOR OR 2SD601ATX
Q907	BC857B	TRANSISTOR OR 2SB709ATX
Q908	2SA1535ARLB	TRANSISTOR
Q909	2SC3944ARLB	TRANSISTOR
Q3351	BC847B	TRANSISTOR OR 2SD601ATX
Q3352	BC857B	TRANSISTOR OR 2SB709ATX
 RESISTOR		
R350	ERQ12AJ151P	FUSIBLE 12W 5% 150Ω ▲
R351	ERJ6GEYJ102	S.M.CARB 0.1W 5% 1KΩ
R352	ERJ6GEYJ102	S.M.CARB 0.1W 5% 1KΩ
R354	ERJ6GEYJ102	S.M.CARB 0.1W 5% 1KΩ
R355	ERG2FJ823	METAL 2W 5% 82KΩ ▲
R356	ERJ6GEY0R00	S.M.CARB 0.1W 5% 0Ω
R357	ERJ6GEYJ822	S.M.CARB 0.1W 5% 8K2Ω
R358	ERDS1TJ821	CARBON 0.5W 5% 820Ω
R359	ERJ6GEYJ334	S.M.CARB 0.1W 5% 330KΩ
R360	ERDS1TJ103	CARBON 0.5W 5% 10KΩ
R361	ERJ6GEYJ102	S.M.CARB 0.1W 5% 1KΩ
R362	ERJ6GEYJ102	S.M.CARB 0.1W 5% 1KΩ
R364	ERJ6GEYJ102	S.M.CARB 0.1W 5% 1KΩ
R365	ERG2FJ823	METAL 2W 5% 82KΩ ▲
R366	ERJ6GEY0R00	S.M.CARB 0.1W 5% 0Ω
R367	ERJ6GEYJ822	S.M.CARB 0.1W 5% 8K2Ω
R368	ERDS1TJ821	CARBON 0.5W 5% 820Ω
R369	ERJ6GEY0R00	S.M.CARB 0.1W 5% 0Ω
R371	ERJ6GEYJ102	S.M.CARB 0.1W 5% 1KΩ
R372	ERJ6GEYJ102	S.M.CARB 0.1W 5% 1KΩ
R374	ERJ6GEYJ102	S.M.CARB 0.1W 5% 1KΩ
R375	ERG2FJ823	METAL 2W 5% 82KΩ ▲
R376	ERJ6GEY0R00	S.M.CARB 0.1W 5% 0Ω
R377	ERJ6GEYJ822	S.M.CARB 0.1W 5% 8K2Ω
R378	ERDS1TJ821	CARBON 0.5W 5% 820Ω
R379	ERJ6GEY0R00	S.M.CARB 0.1W 5% 0Ω
R380	ERJ6GEYJ222	S.M.CARB 0.1W 5% 2K2Ω
R381	ERJ6GEYJ561	S.M.CARB 0.1W 5% 560Ω
R383	ERJ6GEYJ562	S.M.CARB 0.1W 5% 5K6Ω
R385	ERQ12HKR39	METAL 0.5W 5% R39Ω ▲

Ref No.	Part No.	Description
R390	ERDS1TJ184	CARBON 0.5W 5% 180KΩ
R558	ERO50PKF4532	METAL 50W 1% 45KΩ ▲
R905	ERJ6GEYJ681	S.M.CARB 0.1W 5% 680Ω
R906	ERJ6GEYJ393	S.M.CARB 0.1W 5% 39KΩ
R907	ERJ6GEYJ822	S.M.CARB 0.1W 5% 8K2Ω
R908	ERJ6GEYJ471	S.M.CARB 0.1W 5% 470Ω
R909	ERJ6GEYJ102	S.M.CARB 0.1W 5% 1KΩ
R910	ERJ6GEYJ221	S.M.CARB 0.1W 5% 220Ω
R911	ERD25TJ561	CARBON 0.25W 5% 560Ω
R913	ERJ6GEYJ153	S.M.CARB 0.1W 5% 15KΩ
R914	ERJ6GEYJ222	S.M.CARB 0.1W 5% 2K2Ω
R915	ERJ6GEYJ681	S.M.CARB 0.1W 5% 680Ω
R916	ERJ6GEYJ331	S.M.CARB 0.1W 5% 330Ω
R918	ERJ6GEYJ101	S.M.CARB 0.1W 5% 100Ω
R919	ERQ14AJW390	FUSIBLE 14W 5% 39Ω ▲
R920	ERQ14AJW390	FUSIBLE 14W 5% 39Ω ▲
R922	ERD25TJ683	CARBON 0.25W 5% 68KΩ
R923	ERD25TJ683	CARBON 0.25W 5% 68KΩ
R924	ERDS1FYJ390	CARBON 0.5W 5% 39Ω ▲
R925	ERJ6GEY0R00	S.M.CARB 0.1W 5% 0Ω
R926	ERJ6GEY0R00	S.M.CARB 0.1W 5% 0Ω
R927	ERD25TJ122	CARBON 0.25W 5% 1K2Ω
R928	ERD25TJ2R7	CARBON 0.25W 5% 2R7Ω
R929	ERDS1FYJ221	CARBON 0.5W 5% 220Ω
R930	ERD25TJ2R7	CARBON 0.25W 5% 2R7Ω
R931	ERDS1FYJ390	CARBON 0.5W 5% 39Ω ▲
R932	ERDS1FYJ101	CARBON 0.5W 5% 100Ω ▲
R933	ERJ6GEYJ223	S.M.CARB 0.1W 5% 22KΩ
R934	ERJ6GEYJ472	S.M.CARB 0.1W 5% 4K7Ω
R935	ERQ14AJW3R9	FUSIBLE 14W 5% 3R9Ω ▲
R936	ERQ1CJP102	METAL 1W 5% 1KΩ ▲
R937	ERQ14AJW100	METAL 0.25W 5% 10Ω ▲
R938	ERD25TJ122	CARBON 0.25W 5% 1K2Ω
R940	ERD25TJ3R3	CARBON 0.25W 5% 3R3Ω
R941	ERD25TJ3R3	CARBON 0.25W 5% 3R3Ω
R3351	ERJ6GEYJ101	S.M.CARB 0.1W 5% 100Ω
R3352	ERJ6GEYJ472	S.M.CARB 0.1W 5% 4K7Ω
R3353	ERJ6GEYJ474	S.M.CARB 0.1W 5% 470KΩ
R3354	ERJ6GEYJ102	S.M.CARB 0.1W 5% 1KΩ
R3355	ERJ6GEYJ391	S.M.CARB 0.1W 5% 390Ω
 FILTERS		
X1101	CSA5.00MG	CRYSTAL

DIFFERENCES FOR MODEL TX-25XD60S

Ref No.	Part No.	Description	
MISCELLANEOUS COMPONENTS			
4)	TNPA0292AP	Y P.C.B.	△
5)	TLK8E05120	DEGAUSS COIL	△
7)	A59ECF50X71	CRT	△
8)	TKY8E151-2	CABINET	△
9)	TKP8E1168	SPEAKER NET	
10)	TBX8E040	POWER BUTTON BLACK	
11)	TKP8E1173	LEFT PANEL	
12)	TKP8E1171	TOP PANEL	
14)	TQF8E2547	MODEL LABEL	
15)	TKU8E00310	BACK COVER	△
17)	TNPA0295AS	D P.C.B.	△
20)	TNPH0063BP	E P.C.B.	△
26)	TKP8E1201	RIGHT PANEL BLACK	
27)	TKP8E1170	DOOR LID BLACK	
	TPC8E4613	OUTER CARTON	
	TPD8E631	CUSHION TOP	
	TPD8E632	CUSHION BOTTOM	
	TQB8E2415L	RUSSIAN INST BOOK	△
	TQB8E2415M	BULGARIAN INST BOOK	△
	TQB8E2415U	ENGLISH INST BOOK	△

DIFFERENCES FOR MODEL TX-25XD60S/A

MISCELLANEOUS COMPONENTS

10)	TBX8E045	POWER BUTTON DARK WOOD
11)	TKP8E1192	LEFT PANEL DARK WOOD
12)	TKP8E1190	TOP PANEL DARK WOOD
14)	TQF8E2548	MODEL LABEL
26)	TKP8E1202	PANEL RIGHT DARK WOOD
27)	TKP8E1180	DOOR LID DARK WOOD

DIFFERENCES FOR MODEL TX-25XD60S/B

MISCELLANEOUS COMPONENTS

10)	TBX8E046	POWER BUTTON LIGHT WOOD
11)	TKP8E1193	LEFT PANEL LIGHT WOOD
12)	TKP8E1191	TOP PANEL LIGHT WOOD
14)	TQF8E2549	MODEL LABEL
26)	TKP8E1196	RIGHT PANEL LIGHT WOOD
27)	TKP8E1181	DOOR LID LIGHT WOOD

INTEGRATED CIRCUITS

IC1104	X24C0301VM	EAROM
IC1105	27C2001405AA	EPROM
IC2001	MSP3400CPPC6	AUDIO PROCESSOR

CAPACITORS

C352	ECUV1H224ZFX	S.M.CAP	50V	0.22μF	
C353	ECUV1H103KBX	S.M.CAP	50V	10nF	
C354	ECKC2H103J	CERAMIC	50V	10nF	△
C355	ECKC2H102J	CERAMIC	500V	1nF	△
C362	ECUV1H224ZFX	S.M.CAP	50V	0.22μF	
C363	ECUV1H103KBX	S.M.CAP	50V	10nF	
C364	ECKC2H103J	CERAMIC	50V	10nF	△
C365	ECKC2H102J	CERAMIC	500V	1nF	△
C372	ECUV1H224ZFX	S.M.CAP	50V	0.22μF	

Ref No.	Part No.	Description		
C373	ECUV1H103KBX	S.M.CAP	50V 10nF	
C374	ECKC2H103J	CERAMIC	50V 10nF	△
C375	ECKC2H102J	CERAMIC	500V 1nF	△
C381	ECA1HM101GB	ELECT	50V 100μF	
C382	ECA1CM471GB	ELECT	16V 470μF	
C383	ECUV1H103KBX	S.M.CAP	50V 10nF	
C384	ECQM2104KZ	FILM	250V 100nF	
C385	ECEA2EU220	ELECT	250V 22μF	
C386	ECKC3D152J	CERAMIC	2KV 1.5nF	△
C395	ECQM1H104J	FILM	50V 100nF	
C901	ECUV1H030CCX	S.M.CAP	50V 30pF	
C902	ECA1VM101GB	ELECT	35V 100μF	
C903	ECKC1H103JB	CERAMIC	50V 10nF	
C904	ECUV1H103ZFX	S.M.CAP	50V 10nF	
C905	ECA1CM100GB	ELECT	16V 10μF	
C906	ECUV1H102KBX	S.M.CAP	50V 1nF	
C908	ECUV1H151JCX	S.M.CAP	50V 150pF	
C909	ECKC2H472J	CERAMIC	500V 4.7nF	△
C910	ECKC2H472J	CERAMIC	500V 4.7nF	△
C911	ECUV1H151JCX	S.M.CAP	50V 150pF	
C912	ECEA2EU220	ELECT	250V 22μF	
C913	ECA1HM101GB	ELECT	50V 100μF	
C914	ECA1HM101GB	ELECT	50V 100μF	
C915	ECA1CM471GB	ELECT	16V 470μF	
C916	ECEA2EU220	ELECT	250V 22μF	
C917	ECA1HM100GB	ELECT	50V 10μF	
C918	ECUV1H103ZFX	S.M.CAP	50V 10nF	
C919	ECCR2H680J	CERAMIC	500V 68pF	
C2019	ECA1HM101GB	ELECT	50V 100μF	
C3351	ECA1HM101GB	ELECT	50V 100μF	

DIODES

D351	ERA15-04V3	COIL
D352	ERA15-04V3	COIL
D361	ERA15-04V3	COIL
D362	ERA15-04V3	COIL
D371	ERA15-04V3	COIL
D372	ERA15-04V3	COIL
D387	MA2160LFS	DIODE
D901	1SS254T-77	DIODE
D902	1SS254T-77	DIODE
D903	1SS254T-77	DIODE
D3351	1SS254T-77	DIODE

FUSES

F531	ERX2FJ1R0H	METAL	2W	5%	1R0Ω
------	------------	-------	----	----	------

TERMINALS AND LINKS

JSE028	ERJ6GEY0R00	S.M.CARB	0.1W	5%	0Ω
--------	-------------	----------	------	----	----

COILS

L351	SDL5000	DELAY LINE
L352	EXCELD25V	COIL
L353	TLT150K991R	COIL
L361	SDL5000	DELAY LINE
L362	EXCELD25V	COIL
L363	TLT150K991R	COIL
L371	SDL5000	DELAY LINE
L372	EXCELD25V	COIL
L373	TLT150K991R	COIL
L381	TLT220K991R	COIL

Ref No.	Part No.	Description
L2002	TLT100K991R	COIL
TRANSISTORS		
Q901	BC847B	TRANSISTOR OR 2SD601ATX
Q902	BC847B	TRANSISTOR OR 2SD601ATX
Q903	BC847B	TRANSISTOR OR 2SD601ATX
Q904	BC857B	TRANSISTOR OR 2SB709ATX
Q905	BC847B	TRANSISTOR OR 2SD601ATX
Q906	BC847B	TRANSISTOR OR 2SD601ATX
Q907	BC857B	TRANSISTOR OR 2SB709ATX
Q908	2SA1535ARLB	TRANSISTOR
Q909	2SC3944ARLB	TRANSISTOR
Q3351	BC847B	TRANSISTOR OR 2SD601ATX
Q3352	BC857B	TRANSISTOR OR 2SB709ATX
RESISTOR		
R350	ERQ12AJ151P	FUSIBLE 12W 5% 150Ω ▲
R351	ERJ6GEYJ102	S.M.CARB 0.1W 5% 1KΩ
R352	ERJ6GEYJ102	S.M.CARB 0.1W 5% 1KΩ
R354	ERJ6GEYJ102	S.M.CARB 0.1W 5% 1KΩ
R355	ERG2FJ823	METAL 2W 5% 82KΩ ▲
R356	ERJ6GEY0R00	S.M.CARB 0.1W 5% 0Ω
R357	ERJ6GEYJ822	S.M.CARB 0.1W 5% 8K2Ω
R358	ERDS1TJ821	CARBON 0.5W 5% 820Ω
R359	ERJ6GEYJ334	S.M.CARB 0.1W 5% 330KΩ
R360	ERDS1TJ103	CARBON 0.5W 5% 10KΩ
R361	ERJ6GEYJ102	S.M.CARB 0.1W 5% 1KΩ
R362	ERJ6GEYJ102	S.M.CARB 0.1W 5% 1KΩ
R364	ERJ6GEYJ102	S.M.CARB 0.1W 5% 1KΩ
R365	ERG2FJ823	METAL 2W 5% 82KΩ ▲
R366	ERJ6GEY0R00	S.M.CARB 0.1W 5% 0Ω
R367	ERJ6GEYJ822	S.M.CARB 0.1W 5% 8K2Ω
R368	ERDS1TJ821	CARBON 0.5W 5% 820Ω
R369	ERJ6GEY0R00	S.M.CARB 0.1W 5% 0Ω
R371	ERJ6GEYJ102	S.M.CARB 0.1W 5% 1KΩ
R372	ERJ6GEYJ102	S.M.CARB 0.1W 5% 1KΩ
R374	ERJ6GEYJ102	S.M.CARB 0.1W 5% 1KΩ
R375	ERG2FJ823	METAL 2W 5% 82KΩ ▲
R376	ERJ6GEY0R00	S.M.CARB 0.1W 5% 0Ω
R377	ERJ6GEYJ822	S.M.CARB 0.1W 5% 8K2Ω
R378	ERDS1TJ821	CARBON 0.5W 5% 820Ω
R379	ERJ6GEY0R00	S.M.CARB 0.1W 5% 0Ω
R380	ERJ6GEYJ222	S.M.CARB 0.1W 5% 2K2Ω
R381	ERJ6GEYJ561	S.M.CARB 0.1W 5% 560Ω

Ref No.	Part No.	Description
R383	ERJ6GEYJ562	S.M.CARB 0.1W 5% 5K6Ω
R385	ERQ12HKR39	METAL 0.5W 5% R39Ω ▲
R390	ERDS1TJ184	CARBON 0.5W 5% 180KΩ
R558	ERD25TJ823	CARBON 0.25W 5% 82KΩ
R905	ERJ6GEYJ681	S.M.CARB 0.1W 5% 680Ω
R906	ERJ6GEYJ393	S.M.CARB 0.1W 5% 39KΩ
R907	ERJ6GEYJ822	S.M.CARB 0.1W 5% 8K2Ω
R908	ERJ6GEYJ471	S.M.CARB 0.1W 5% 470Ω
R909	ERJ6GEYJ102	S.M.CARB 0.1W 5% 1KΩ
R910	ERJ6GEYJ221	S.M.CARB 0.1W 5% 220Ω
R911	ERD25TJ561	CARBON 0.25W 5% 560Ω
R913	ERJ6GEYJ153	S.M.CARB 0.1W 5% 15KΩ
R914	ERJ6GEYJ222	S.M.CARB 0.1W 5% 2K2Ω
R915	ERJ6GEYJ681	S.M.CARB 0.1W 5% 680Ω
R916	ERJ6GEYJ331	S.M.CARB 0.1W 5% 330Ω
R918	ERJ6GEYJ101	S.M.CARB 0.1W 5% 100Ω
R919	ERQ14AJW390	FUSIBLE 14W 5% 39Ω ▲
R920	ERQ14AJW390	FUSIBLE 14W 5% 39Ω ▲
R922	ERD25TJ683	CARBON 0.25W 5% 68KΩ
R923	ERD25TJ683	CARBON 0.25W 5% 68KΩ
R924	ERDS1FYJ390	CARBON 0.5W 5% 39Ω ▲
R925	ERJ6GEY0R00	S.M.CARB 0.1W 5% 0Ω
R926	ERJ6GEY0R00	S.M.CARB 0.1W 5% 0Ω
R927	ERD25TJ122	CARBON 0.25W 5% 1K2Ω
R928	ERD25TJ2R7	CARBON 0.25W 5% 2R7Ω
R929	ERDS1FYJ221	CARBON 0.5W 5% 220Ω
R930	ERD25TJ2R7	CARBON 0.25W 5% 2R7Ω
R931	ERDS1FYJ390	CARBON 0.5W 5% 39Ω ▲
R932	ERDS1FYJ101	CARBON 0.5W 5% 100Ω ▲
R933	ERJ6GEYJ223	S.M.CARB 0.1W 5% 22KΩ
R934	ERJ6GEYJ472	S.M.CARB 0.1W 5% 4K7Ω
R935	ERQ14AJW3R9	FUSIBLE 14W 5% 3R9Ω ▲
R936	ERQ1CJP102	METAL 1W 5% 1KΩ ▲
R937	ERQ14AJW100	METAL 0.25W 5% 10Ω ▲
R938	ERD25TJ122	CARBON 0.25W 5% 1K2Ω
R940	ERD25TJ3R3	CARBON 0.25W 5% 3R3Ω
R941	ERD25TJ3R3	CARBON 0.25W 5% 3R3Ω
R3351	ERJ6GEYJ101	S.M.CARB 0.1W 5% 100Ω
R3352	ERJ6GEYJ472	S.M.CARB 0.1W 5% 4K7Ω
R3353	ERJ6GEYJ474	S.M.CARB 0.1W 5% 470KΩ
R3354	ERJ6GEYJ102	S.M.CARB 0.1W 5% 1KΩ
R3355	ERJ6GEYJ391	S.M.CARB 0.1W 5% 390Ω
FILTERS		
X1101	CSA5.00MG	CRYSTAL

SCHEMATIC DIAGRAM FOR MODELS
TX-28XD60P/TX-25XD60P
TX-28XD60S/TX-25XD60S
(Euro-3H Chassis)

IMPORTANT SAFETY NOTICE

Components identified by  mark have special characteristics important for safety. When replacing any of these components, use only manufacturer's specified parts.

Notes

1. RESISTOR

All resistors are carbon 1/4W resistor, unless marked as follows:
Unit of resistance is OHM (Ω) (K=1,000, M=1,000,000).

2. CAPACITORS

All capacitors are ceramic 50V, unless marked as follows:
Unit of capacitance is μ F, unless otherwise stated.

3. COIL



Unit of inductance is μ H, unless otherwise stated.

4. Components marked 'L' on the schematic diagram shows leadless parts.

5. TEST POINT

 : Test Point position

6. EARTH SYMBOL

 : Chassis Earth (Cold)  : Line Earth (Hot)

7. VOLTAGE MEASUREMENT

Voltage is measured by a DC voltmeter.

Measurement conditions are as follows:

Power source	AC 220V-240V, 50Hz
Receiving Signal	Colour Bar signal (RF)
All customer controls	Maximum position

8.  : Indicates the Video signal path

 : Indicates the Audio signal path

 : Indicates the Vertical/Horizontal signal path

9. This schematic diagram is the latest at the time of printing and is subject to change without notice.

Remarks

1. The Power Circuit contains a circuit area which uses a separate power supply to isolate the earth connection. The circuit is defined by HOT and COLD indications in the schematic diagram. All circuits, except the Power Circuit, are COLD. Take the following precautions:

Precautions

- Do not touch the hot part, or the hot and cold parts at the same time, as you are liable to a shock hazard.
- Do not short-circuit the hot and cold circuits as electrical components may be damaged.
- Do not connect an instrument, such as an oscilloscope, to the hot and cold circuits simultaneously, as this may cause fuse failure. Connect the earth of the instruments to the earth connection of the circuit being measured.
- Make sure to disconnect the power plug before removing the chassis.

B BOARD
TNPA0317

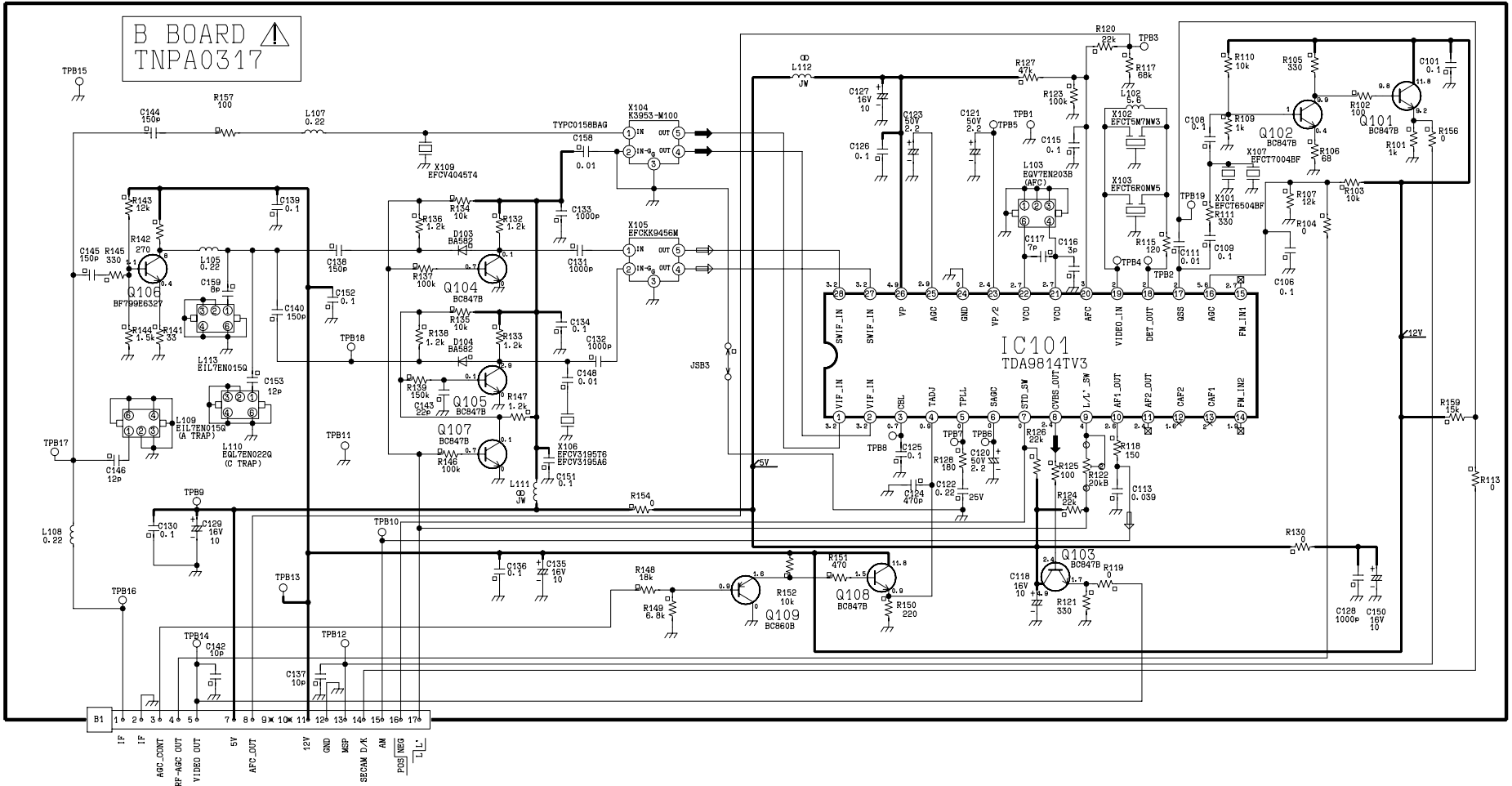

- 1 IF
- 2 IF
- 3 ARC_OUT
- 4 RF-ARC_OUT
- 5 VIDEO_OUT
- 6 5V
- 7 AFC_OUT
- 8 12V
- 9 GND
- 10 MSP
- 11 SECAM_D/K
- 12 AM
- 13 PGS/NEG
- 14
- 15
- 16
- 17

D BOARD
TNPA0295

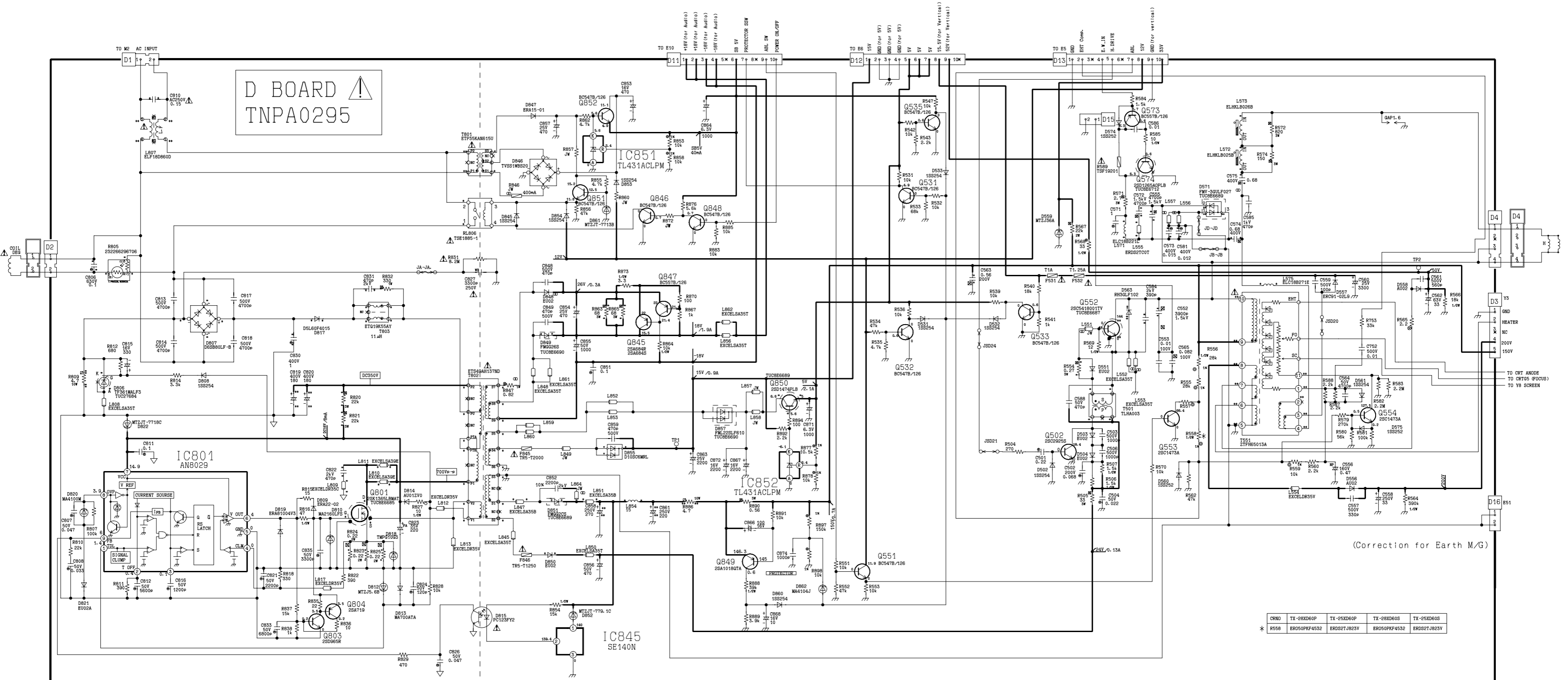

CRNO	TX-28XD60P	TX-25XD60P	TX-28XD60S	TX-25XD60S
* R556	ER050PKF4532	ER052TJ823V	ER050PKF4532	ER052TJ823V

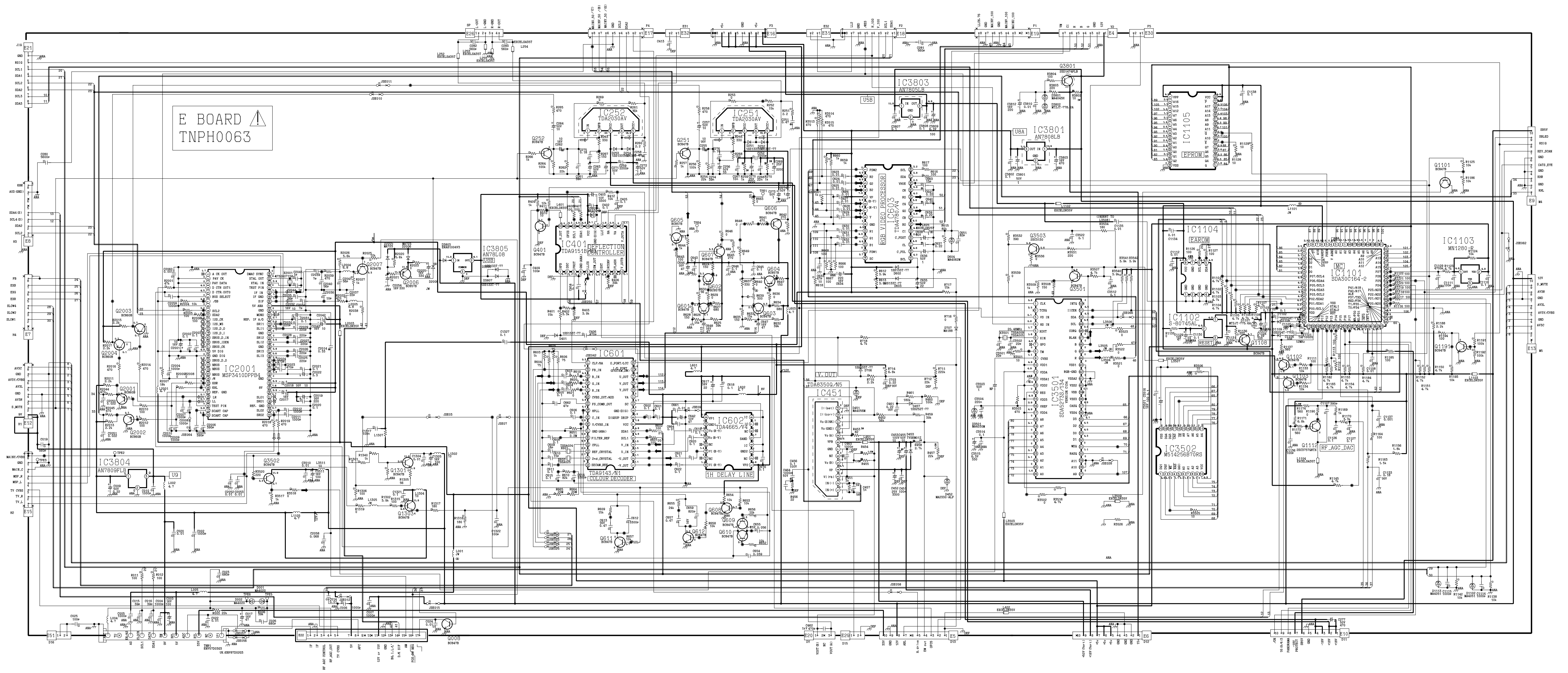

Back Cover

F BOARD
TNPA0756

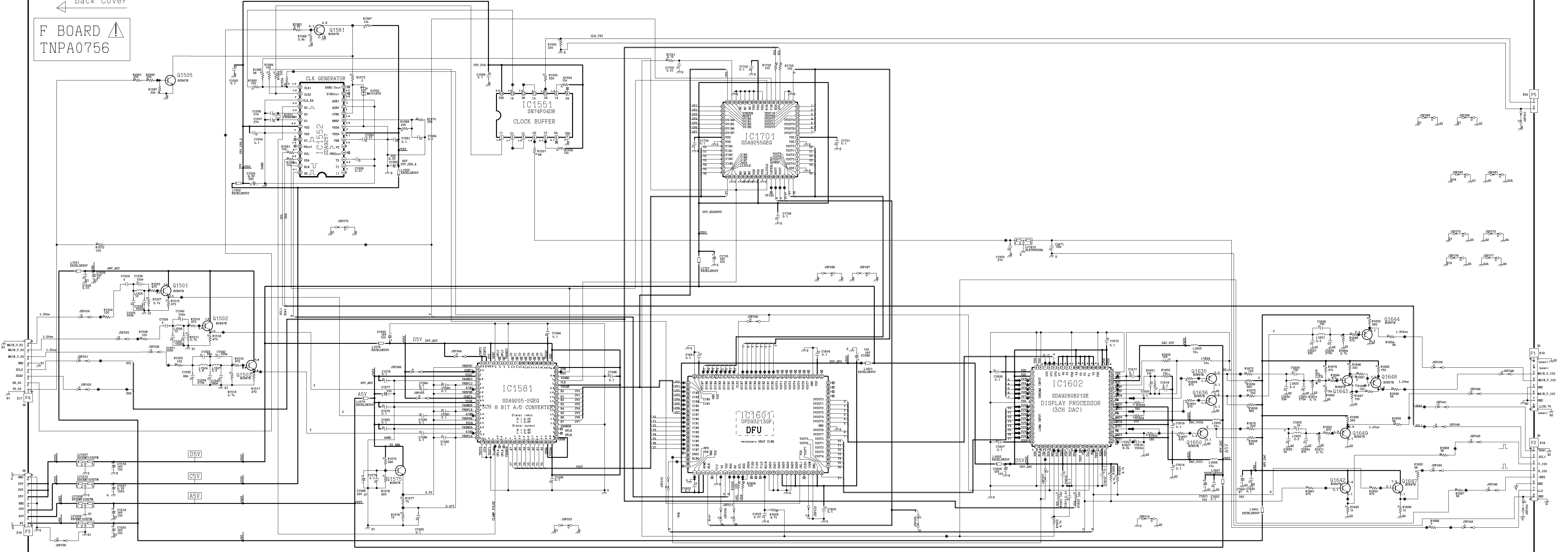

H BOARD
TNPA0293

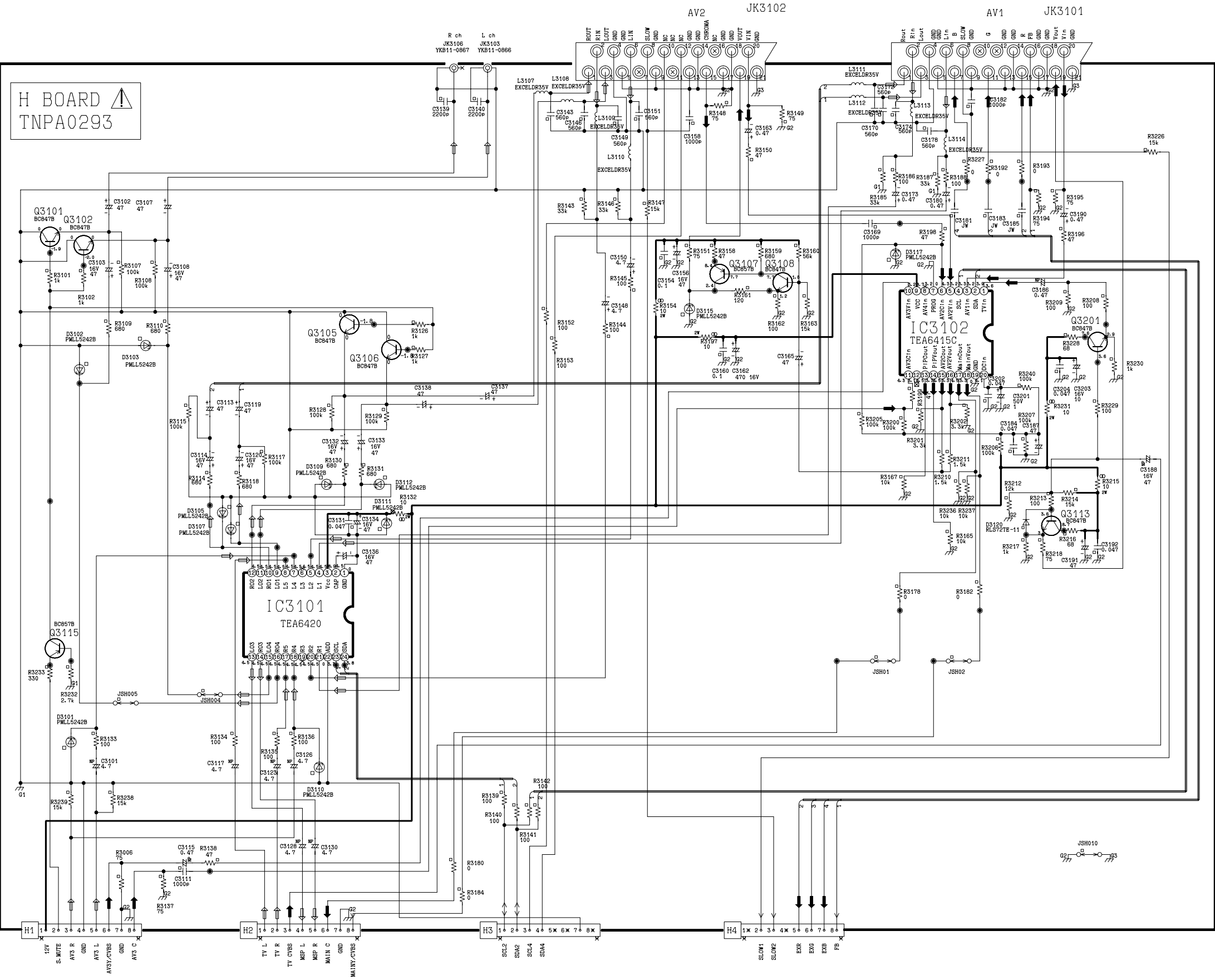

AV2 JK3102

AV1 JK3101

R ch L ch
JK3106 JK3103
YKB11-0867 YKB11-0866

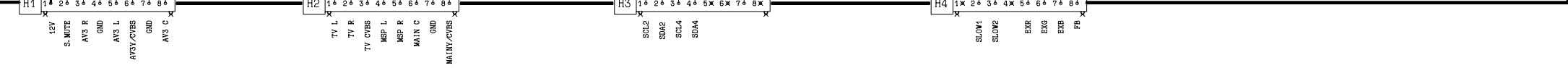

M BOARD
TNPA0766

COLD

HOT

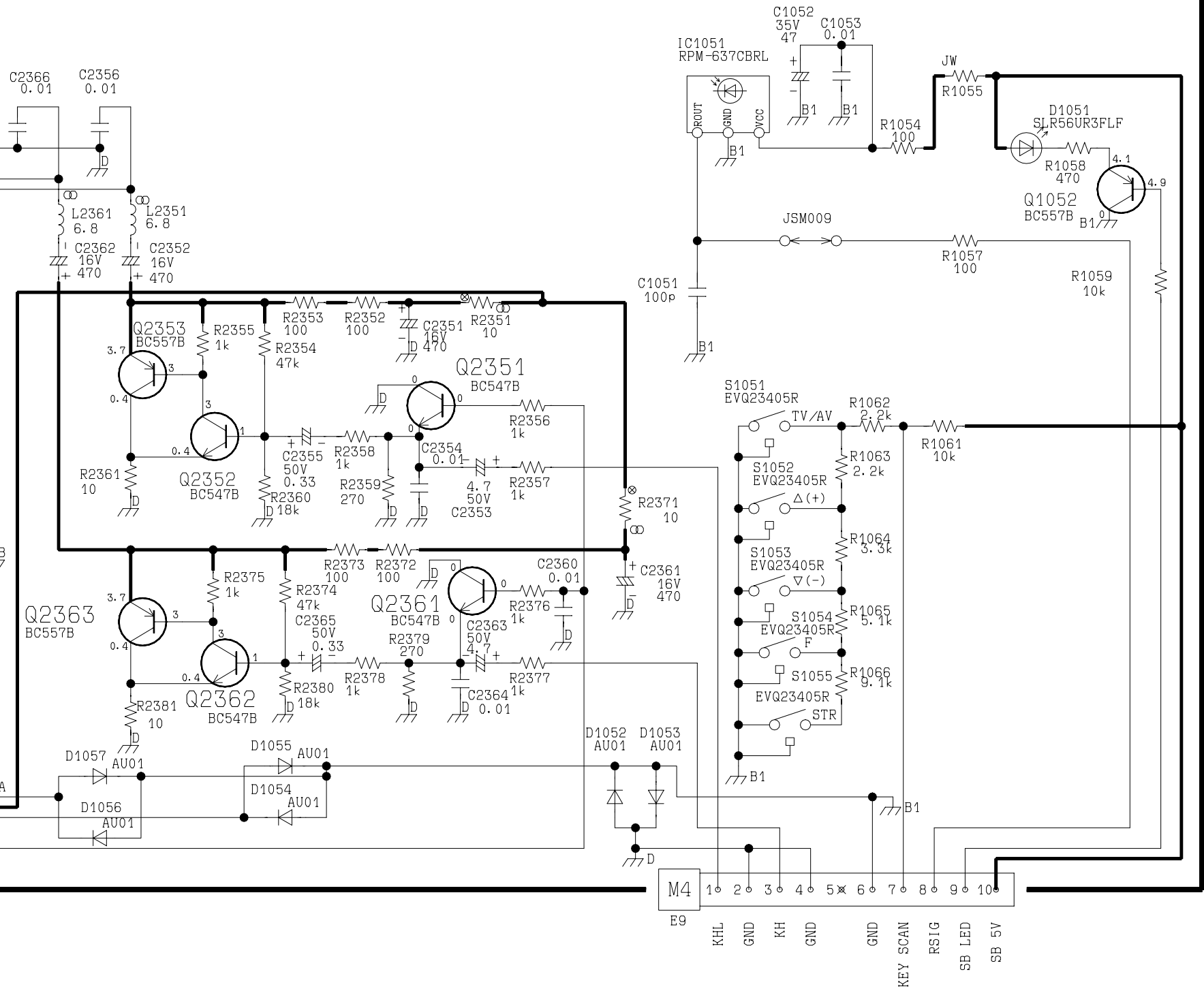
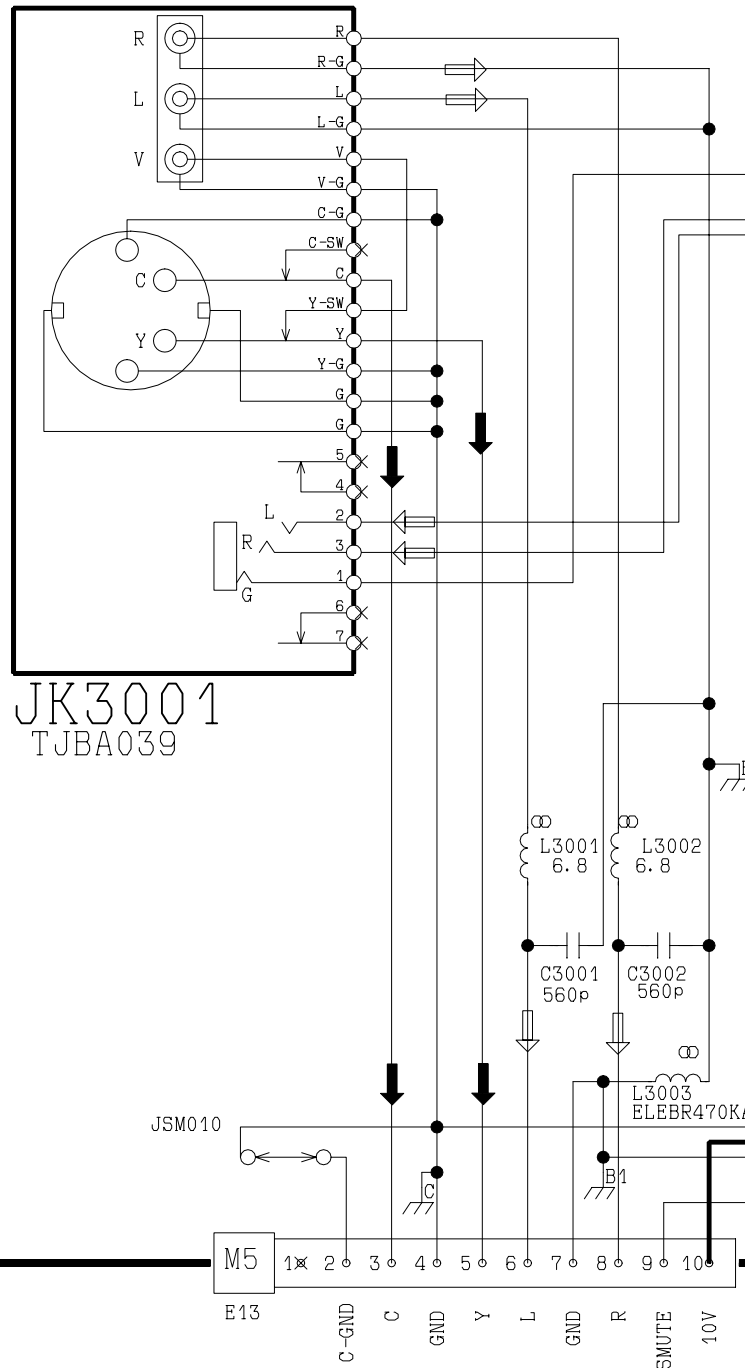
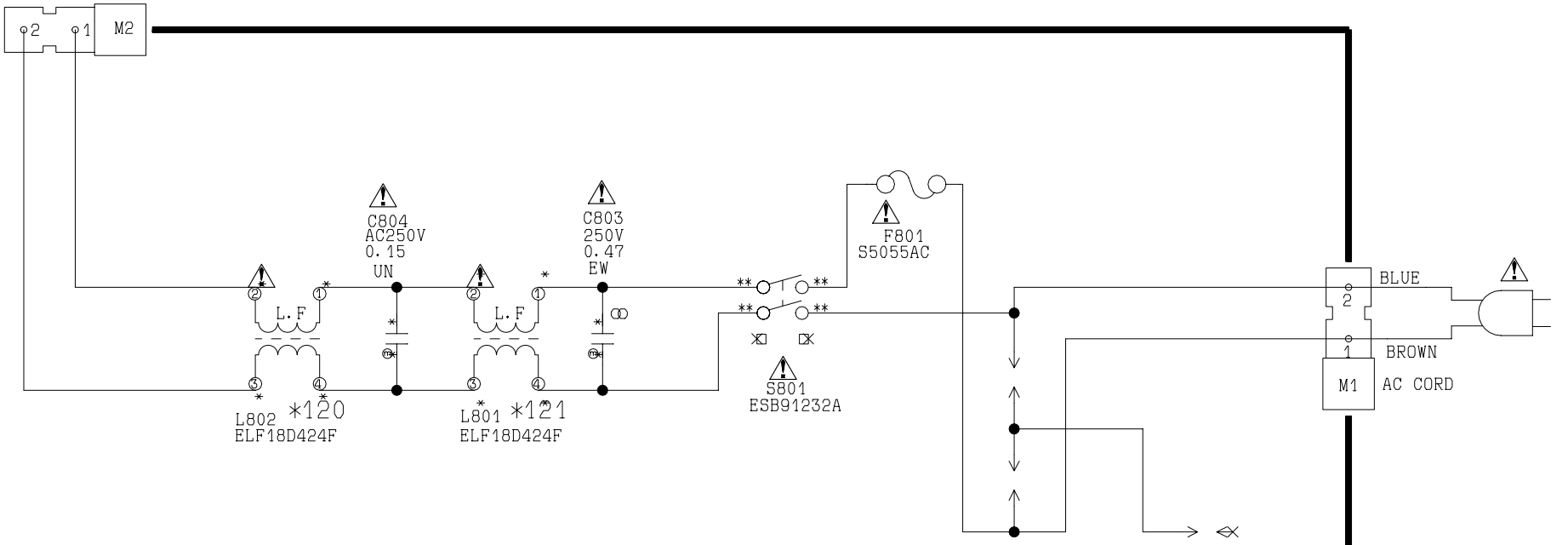

Y BOARD ⚠️
TNPA0292

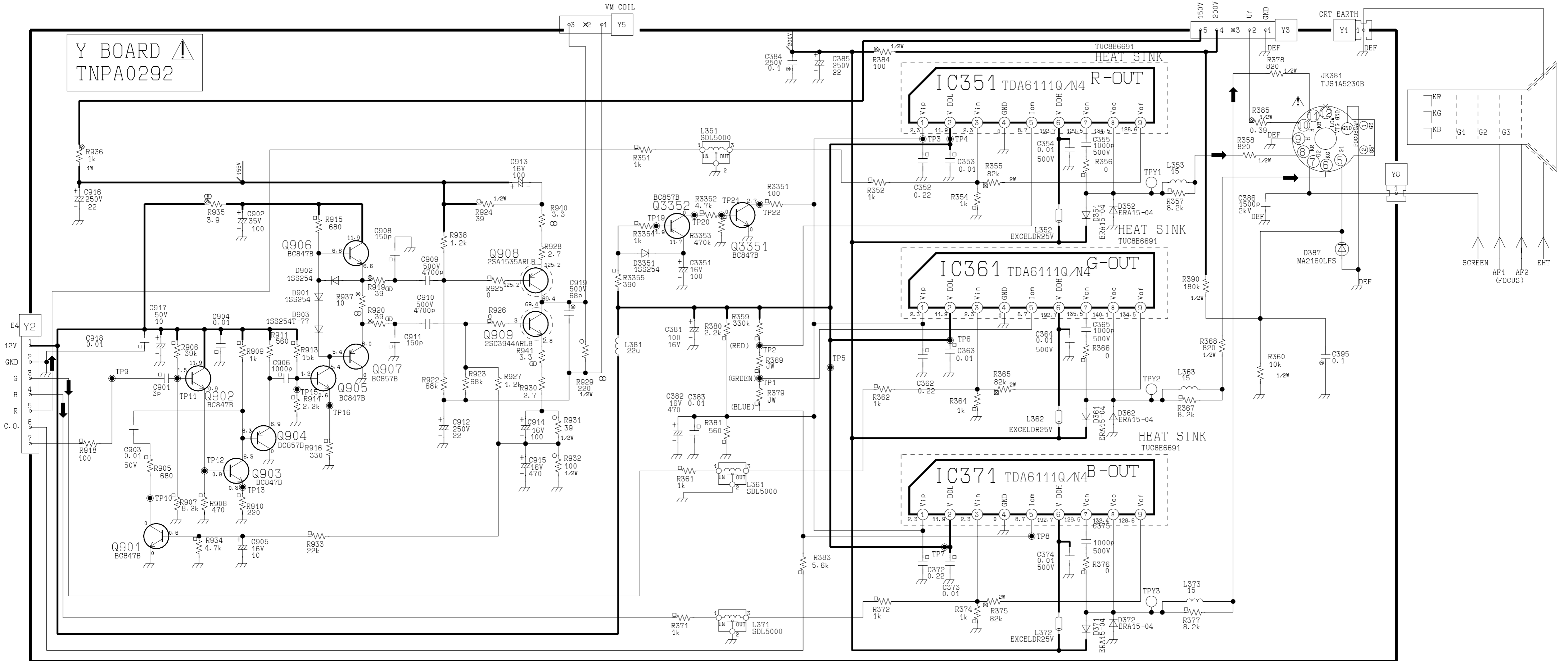

TNP A0317

(B2)

SEE REVERSE FOR ORDER NO.

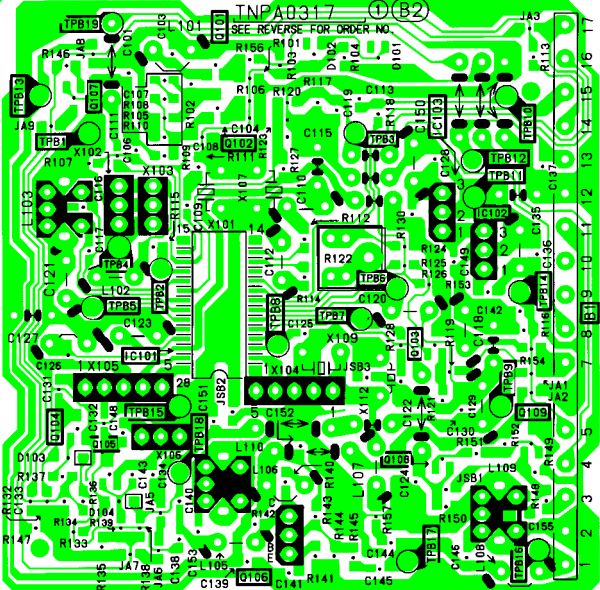

16
15
14
13
12
11
10
9
8
7
6
5
4
3
2

1
2
3
4
5
6
7
8
9
10
11
12
13
14
15
16

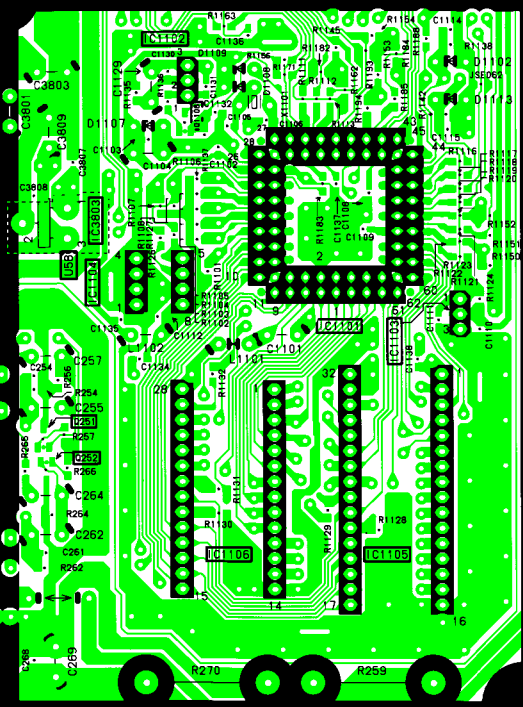
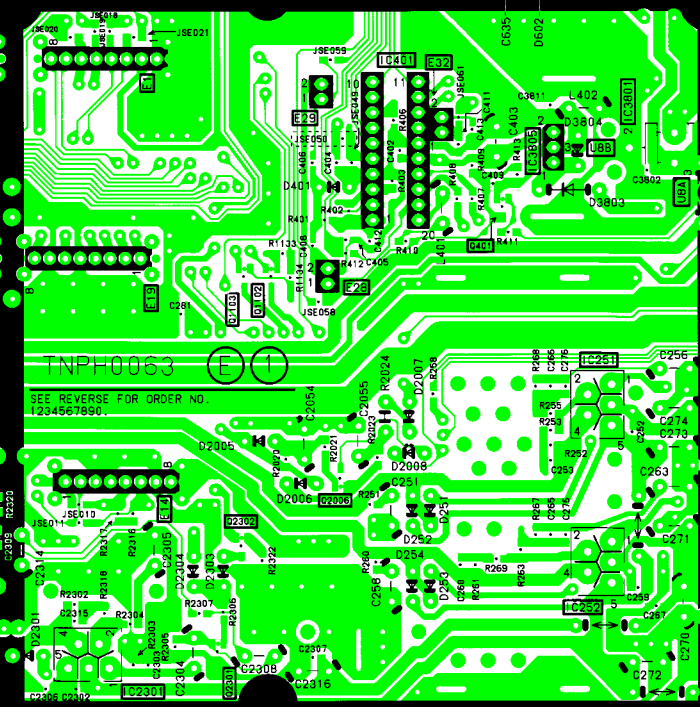
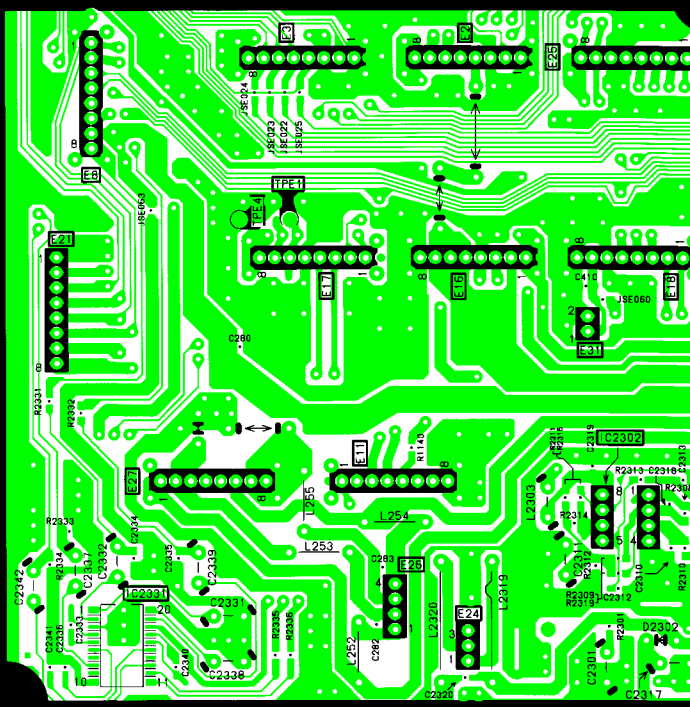
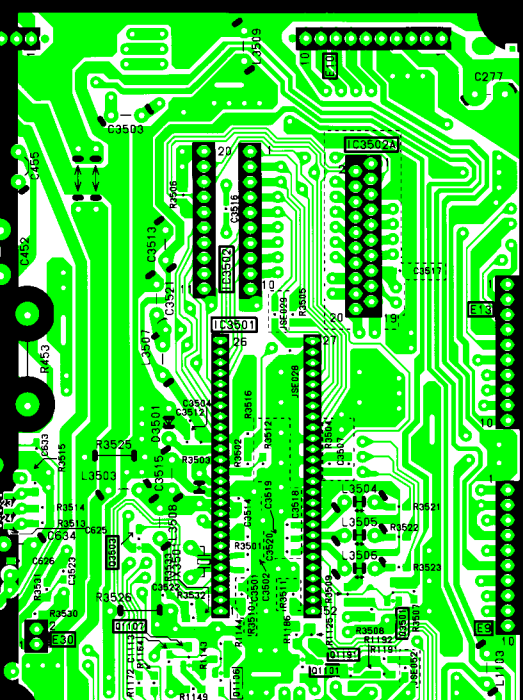
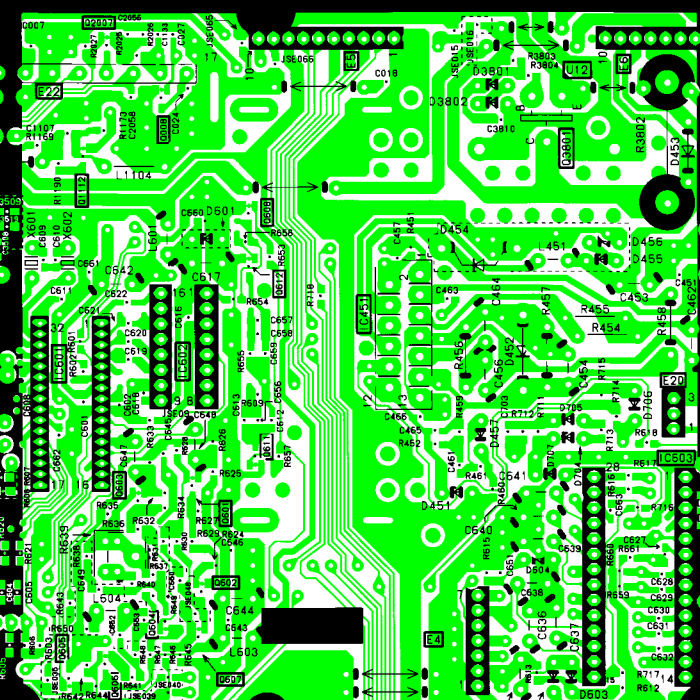
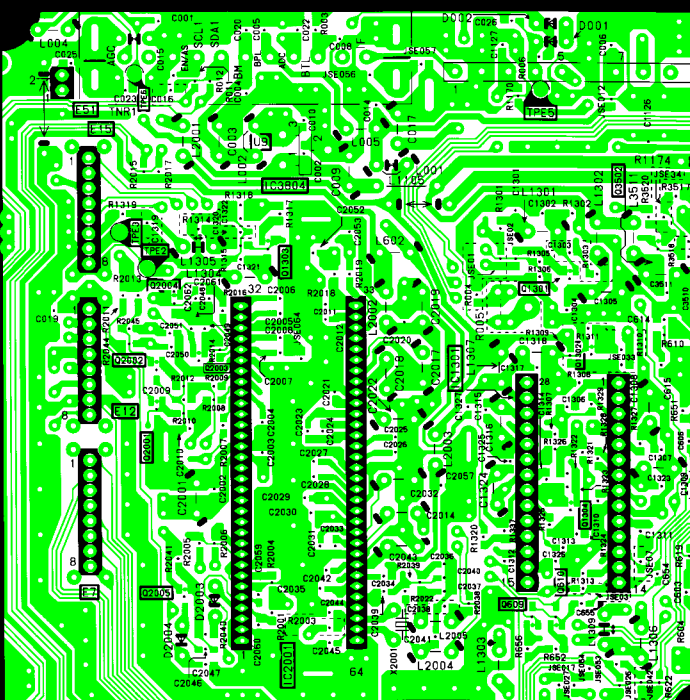

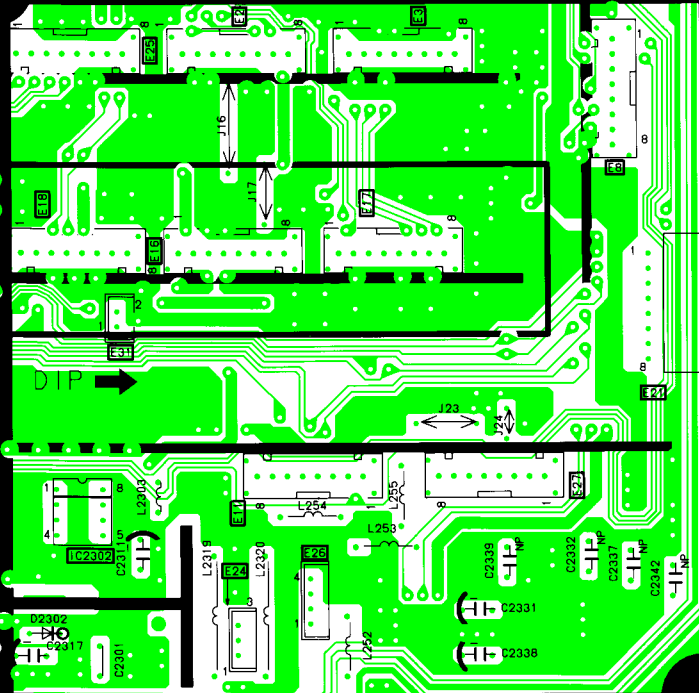
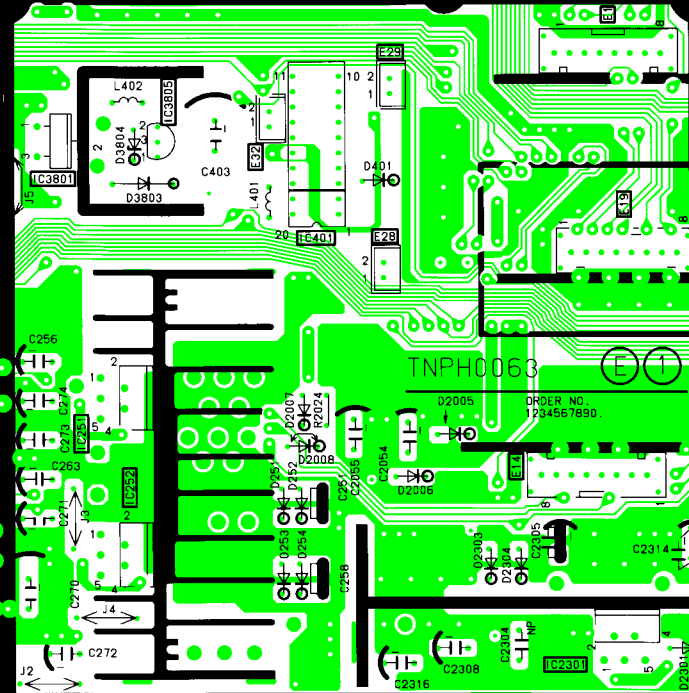
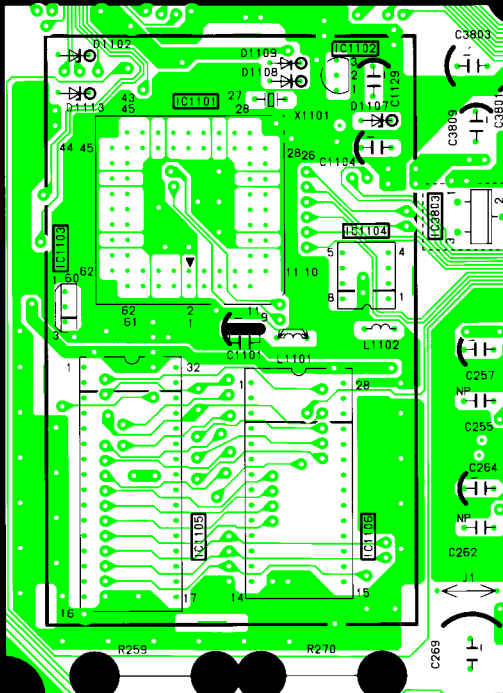
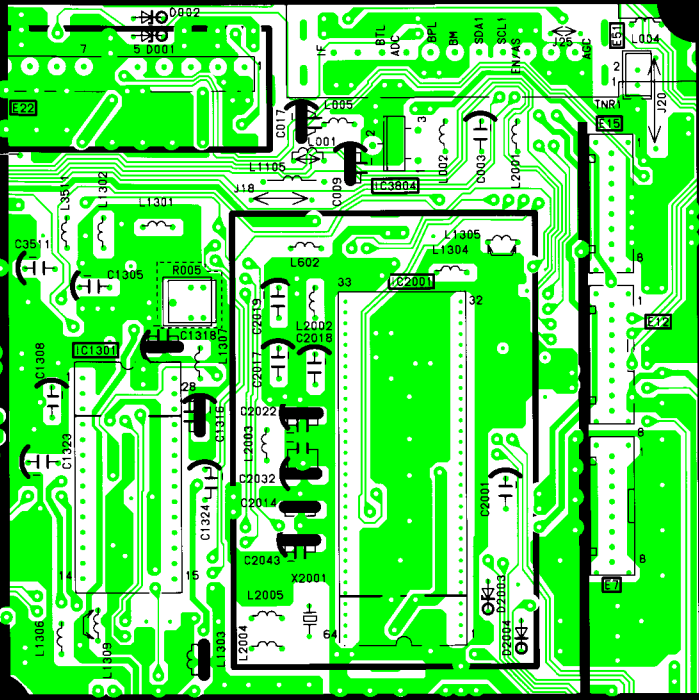
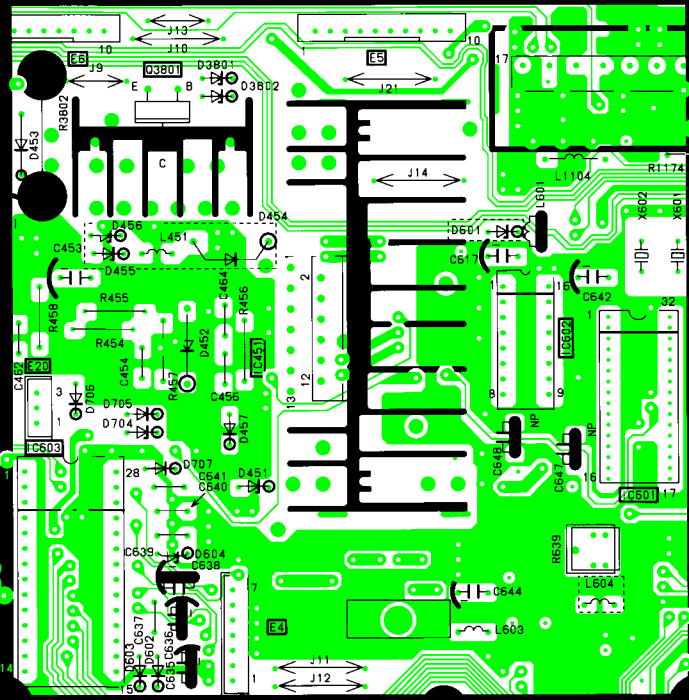
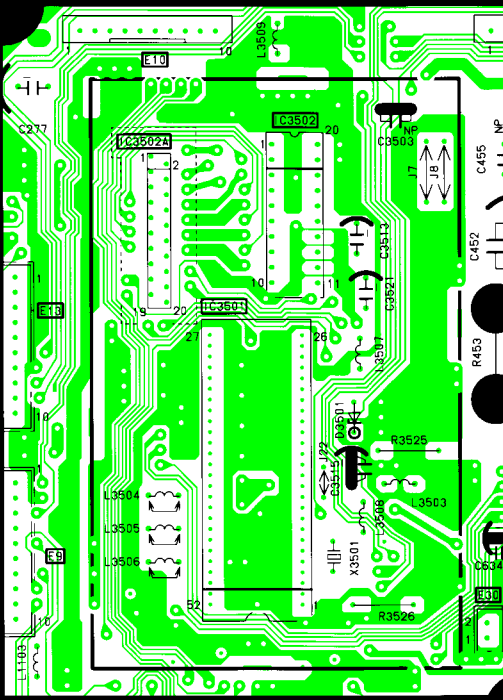

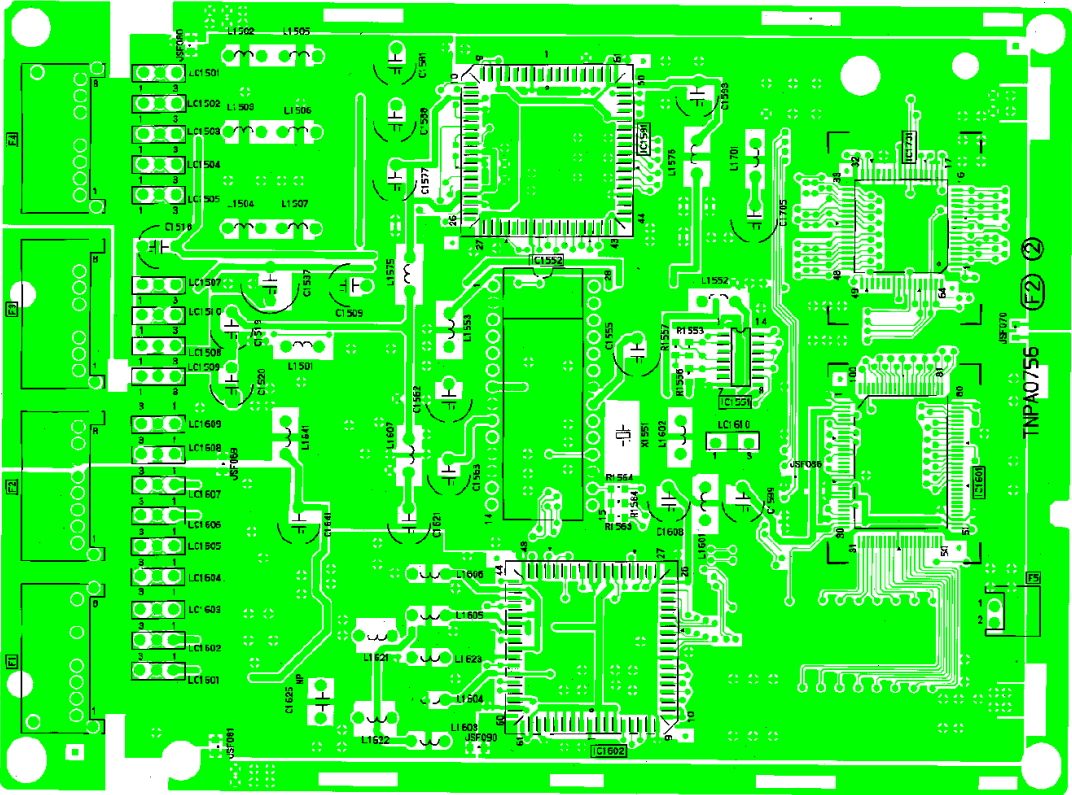

TNPA0756

F2

F1

F3

F4

F5

F6

F7

F8

F9

F10

F11

F12

F13

F14

F15

F16

F17

F18

F19

F20

F21

F22

F23

F24

F25

F26

F27

F28

F29

F30

F31

F32

F33

F34

F35

F36

F37

F38

F39

F40

F41

F42

F43

F44

F45

F46

F47

F48

F49

F50

F51

F52

F53

F54

F55

F56

F57

F58

F59

F60

F61

F62

F63

F64

F65

F66

F67

F68

F69

F70

F71

F72

F73

F74

F75

F76

F77

F78

F79

F80

F81

F82

F83

F84

F85

F86

F87

F88

F89

F90

F91

F92

F93

F94

F95

F96

F97

F98

F99

F100

F101

F102

F103

F104

F105

F106

F107

F108

F109

F110

F111

F112

F113

F114

F115

F116

F117

F118

F119

F120

F121

F122

F123

F124

F125

F126

F127

F128

F129

F130

F131

F132

F133

F134

F135

F136

F137

F138

F139

F140

F141

F142

F143

F144

F145

F146

F147

F148

F149

F150

F151

F152

F153

F154

F155

F156

F157

F158

F159

F160

F161

F162

F163

F164

F165

F166

F167

F168

F169

F170

F171

F172

F173

F174

F175

F176

F177

F178

F179

F180

F181

F182

F183

F184

F185

F186

F187

F188

F189

F190

F191

F192

F193

F194

F195

F196

F197

F198

F199

F200

F201

F202

F203

F204

F205

F206

F207

F208

F209

F210

F211

F212

F213

F214

F215

F216

F217

F218

F219

F220

F221

F222

F223

F224

F225

F226

F227

F228

F229

F230

F231

F232

F233

F234

F235

F236

F237

F238

F239

F240

F241

F242

F243

F244

F245

F246

F247

F248

F249

F250

F251

F252

F253

F254

F255

F256

F257

F258

F259

F260

F261

F262

F263

F264

F265

F266

F267

F268

F269

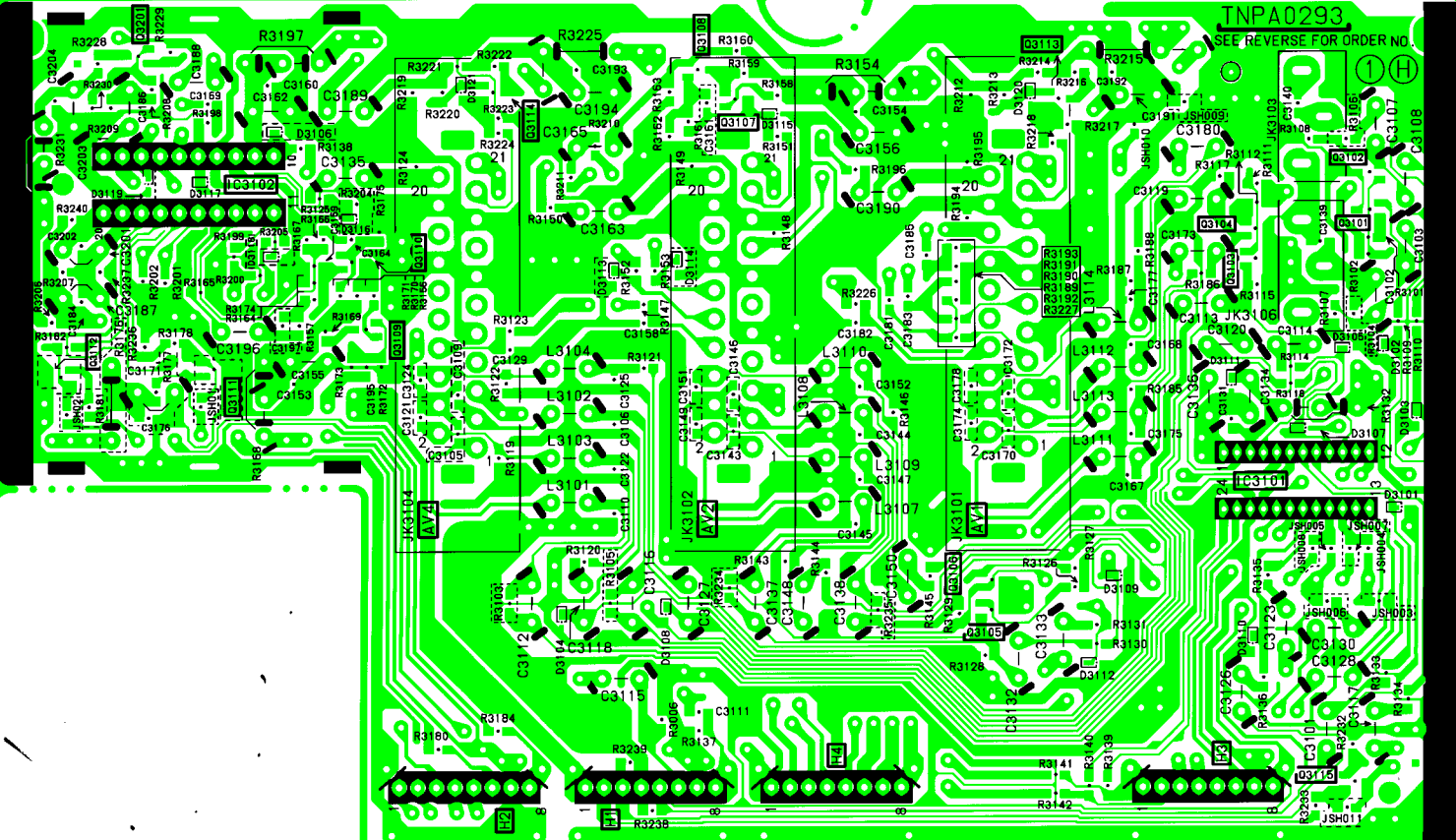

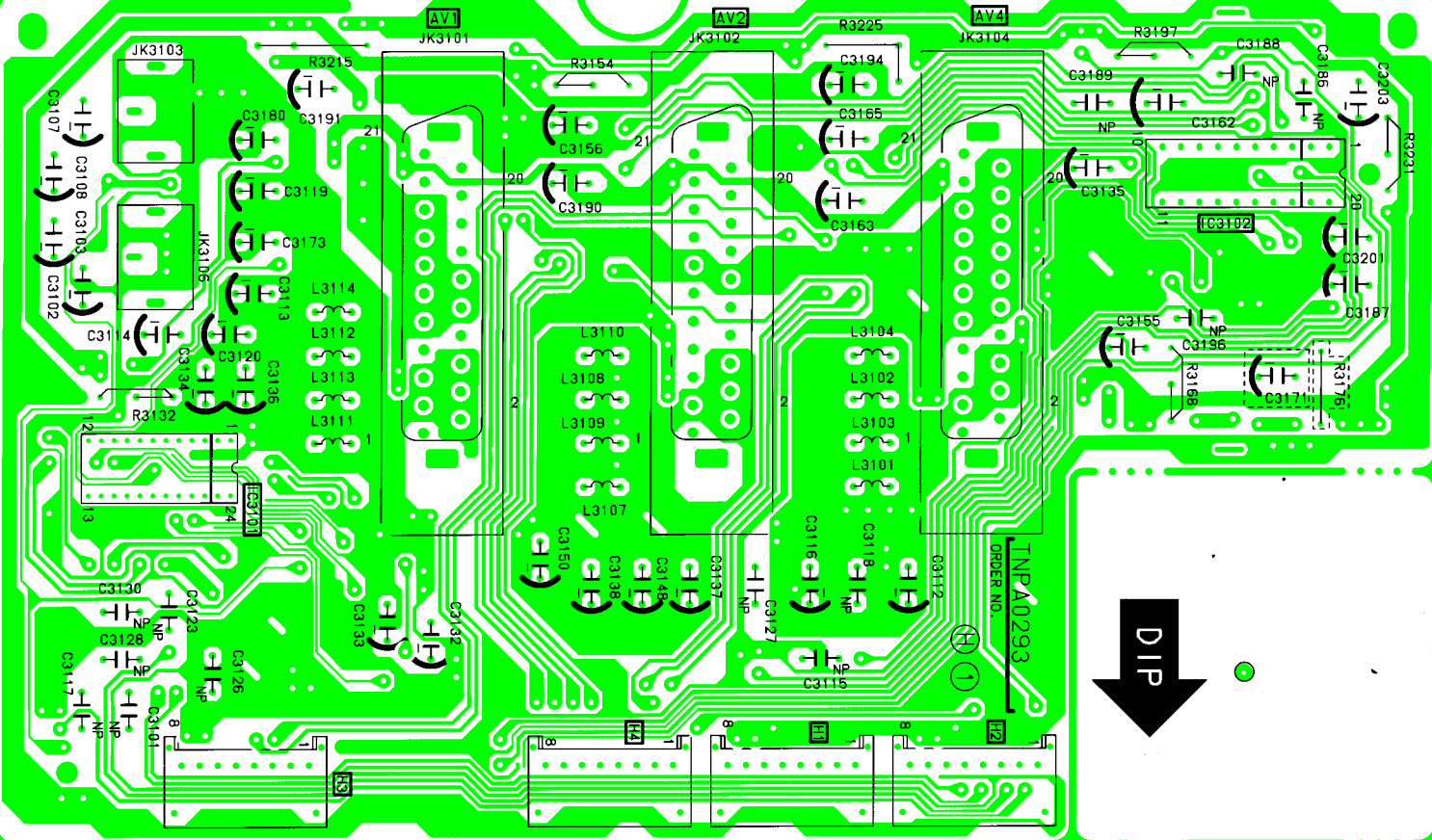

DIP

TNP40293

ORDER NO.

TNPA0292

SEE REVERSE FOR ORDER NO.

(2) (Y)

H.V. DANGER

JK381

